



COURSE HANDOUT

PERSONAL SURVIVAL TECHNIQUES



NAVIGATOR MARITIME ACADEMY

(Approved by DG Shipping, Ministry of Shipping, Govt. of India)

(MTI No. : 108025 & Approval No.: TR/A/58/2019)

Plot No – 342, Fathepur Sikri Road, Patholi, Agra, Uttar Pradesh

Tel No: +91-8006891234

E-mail: training@navigatormaritime.ac.in

Web: www.navigatormaritime.ac.in

CHAPTER 1 – INTRODUCTION SAFETY AND SURVIVAL

1001. The value of regular training of all personnel in lifeboat, life raft and any survival equipment cannot be over-emphasised. Personnel must be always prepared to respond to any emergency necessitating launching, embarkation or manning of survival craft and equipment. There is no substitute for thorough knowledge, periodic training and practical drills in regard to survival at sea.

Principle of Survival at Sea

1002. The principles of survival at sea are :

- (a) Regular Training and Drills
- (b) Preparedness for any emergency
- (c) Knowledge of action to be taken :
 - (i) When called to survival craft stations
 - (ii) When required to abandon ship
 - (iii) When in the water
 - (iv) When aboard a survival craft.
- (d) Knowledge of the main dangers to survivors.

Definitions

1003. The various definitions as associated with survival craft and appliances are listed below:

- (a) Survival Craft is a craft capable of sustaining the lives of persons in distress from the time of abandoning the ship.
- (b) Rescue Boat is a boat designed to rescue persons in distress and to marshal survival crafts.
- (c) Free fall launching is that method of launching a survival craft whereby the craft with its compliment of persons and equipment on board is released and allowed to fall into the sea without any restraining apparatus.
- (d) Inflatable appliance is an appliance which depends upon non-rigid, gas filled chambers for buoyancy and which is normally kept uninflated until ready for use.
- (e) Immersion Suit is a protective suit, which reduces the body heat loss of a person wearing it in cold water.
- (f) Thermal Protective Aid is a bag or suit made of waterproof material with low thermal conductivity.

- (g) Launching Appliance is a means of transferring a survival craft or rescue boat from its stowed position safely to water.

CHAPTER 2 – EMERGENCY SITUATIONS

2001. An emergency is not qualified by time, place or season. It may occur at any time. This is particularly true of life at sea. A mariner so often encounters the elements of nature first hand. Modern technology has greatly advanced in improving ship design, better life saving and survival equipment navigational aids and weather forecasting. Nevertheless risks, dangers and uncertainties associated with passage by sea still exist.

2002. The present day seafarer can be however much better prepared and equipped to tackle an emergency at sea even when there may arise a need to “abandon ship”. The chances of survival at sea are much higher today than ever before.

Types of Emergencies

2003. The various emergencies that may occur at sea are :

- (a) Fire
- (b) Collision
- (c) Gas Explosion
- (d) Flooding
- (e) Shifting of Cargo
- (f) Gas leak
- (g) Stranding
- (h) Engine failure
- (i) Unforeseen mishap such as an accident, serious illness
- (j) Foundering.
- (k) DG – GBRGO

Precautions

2004. Precautions should be taken in all aspects of ship operations so that such emergencies do not occur. General precautions consist of :

- (a) Safe Navigation of the Vessel
- (b) Fire Prevention
- (c) Proper handling, stowage and care of cargo.
- (d) Training of crew and regular practice of emergency drills aboard ships.

Fire Provisions

2005. All vessels are well equipped with adequate appliance for fire fighting to tackle any fire that may occur on board. The means available to fight a fire are :

- (a) Fire pumps, pipelines, hydrants, hoses and nozzles.
- (b) Fixed fire detection and extinguishing system such as sprinkler system, inert gas system, CO₂ system, foam system etc.

- (c) Various types of fire extinguishers to suit location and expected types of fires. Types of extinguisher, normally provided are water / CO₂, foam, dry chemical powder, CO₂ etc.
- (d) Personal protection and safety equipment, such as : breathing apparatus sets, fire protection suits and an array of safety gear.
- (e) Design and construction of the vessel which contributes immensely in restricting the spread of fire.

Foundering

2006. A vessel is said to “founder” when she has lost her reserved buoyancy and / or has become unstable and is consequently unable to stay afloat.

2007. Foundering is prevented by the water – tight integrity and stability of the vessel. In order to maintain the water tight integrity of a vessel, it is essential that all watertight closing appliances, such as : Hatch covers, water tight doors, bow stern and side doors and ramps, ducts etc. are securely closed and battened down prior proceeding to sea.

2008. Further, in case of ingress of water, resulting in flooding and/or bulging of a watertight space or compartment, means are provided to pump out the water by the bilge and ballast systems.

Crew Expertise

2009. The human resource factor is absolutely vital to the tackling of emergency situations that arise on board. It is therefore essential the ship’s crew is competent, skilled and thoroughly familiar with the operating environment. They must be fully schooled in safe working procedures. They should be well trained in the operation of life saving and fire fighting appliances and be fully geared to handle any emergency.

2010. Regular conduct of emergency procedure training and drills will establish which crew members should be given a particular emergency duty. This is essential to the success of the emergency procedure. Crew should be thoroughly familiar with boat and fire drills. It is essential that in an emergency, if the order to abandon ship is given, the same be carried out in an organised and disciplined manner. There should be a sense of urgency without resorting to any panic or commotion.

Muster List and Emergency Signals

2011. The Muster List provides clear instructions for every person to follow in the event of an emergency. The Muster List is exhibited in conspicuous locations throughout the ship, including navigation bridge, machinery space and crew / passenger accommodation spaces. Illustrations and instructions in the appropriate language are also posted in conspicuous locations, crew/passenger cabins and displayed at muster stations / notice boards to inform crew and passengers with regard to :-

- (a) Their muster station.
- (b) The essential actions that they should take in an emergency.
- (c) The proper method of donning life jackets.

Jumping into the Water Wearing a Lifejacket.

2012. **Embark Dry.** The survivors should try to board the survival craft dry preferably onboard the ship before it is lowered and should avoid jumping into the water. But in case a survivor misses the boat, he should try to get into the survival craft by means of a ladder or a rope.

2013 **Be ready to jump.** Quite often it becomes essential for the survivors to jump into the water and in that case they should not jump into the water from a height greater than 6 meters (20 ft.). If the survivors have to hump they should jump near the slightly ahead of the survival craft wearing the lifejacket.

2014 **Jump Correctly.** It is important that the correct procedure for jumping into the water is followed, which is stated below :-

- (a) Block off nose and mouth.
- (b) Hold the lifejacket with the other hand.
- (c) Keep the feet together.
- (d) Check below to see that it is all clear in the water. NEVER jump into the boats or on top of the rafts from a height.
- (e) Look ahead, parallel to the horizon and jump with the feet first.
- (f) After jumping into the water, swim and get into the survival craft as fast as possible.

The General Emergency Alarm Signal

2015 It is provided to alert all crew and passengers of an emergency. The general emergency alarm system is capable of sounding the general alarm signal consisting of seven or more short blasts followed by one long blast on the ship's whistle or siren and additionally on an electrically operated bell or klaxon or other equivalent warning system. The system is powered from both the ship's mains supply and the emergency source of electrical power.

2016 The system is capable of operation from the Navigation Bridge and except for the ship's whistle, also from other strategic points. The system shall be audible throughout the accommodation and normal crew working spaces and supplemented by a public address system or other suitable communication system.

2017 An emergency communication system comprising of either fixed or portable equipment's or both is provided for two-way communication between emergency control stations, muster and embarkation stations and command centre.

Emergency Drills

2018 Should be held at regular intervals to familiarise crew and passengers about their muster stations, duties and use of survival and emergency equipment. Frequent practice builds up confidence and contributes significantly in the successful handling of an emergency.

2019 Practice emergency musters and drills are required to be carried out at regular intervals, as enumerated below :

- (a) **On Cargo Ships:** Each member of the crew shall participate in at least one Abandon Ship Drill and Fire Drills every month. The drills of the crew shall take place within 24 hours of the ship leaving a port if more than 25% of the crew have not participated in abandon ship and fire drills on board that particular ship in the previous month.
- (b) On Passenger ships : On a ship engaged on an International voyage, which is not a short International voyage, musters of the passengers shall take place within 24 hours after embarkation.
- (c) Passengers shall be instructed in the use of life jackets and actions to be taken in the event of an emergency. If only a small number of passengers embark at a port after the muster has been held it shall be sufficient, instead of holding another muster, to draw the attention of these passengers to the emergency instructions.
- (d) An abandon ship drill and a fire drill shall take place weekly.

Crew and Emergency Instructions :

2020. Personnel should, as soon as possible after joining a ship, acquire knowledge of:

- (a) The meaning of emergency signals.
- (b) Instructions on the muster list and their duties.
- (c) The location and use of life saving equipment.
- (d) The location and use of fire-fighting equipment.
- (e) Escape routes and equipment.
- (f) Emergencies involving the sinking of the ship.
- (g) The means provided for survival on ship and survival craft.

Extra Equipment And Survival

2021 Survival crafts are adequately provisioned and provided with drinking water and equipment. However, time permitting, effort should be made to supplement the aforesaid by taking extra materials from the sinking ship.

2022 In case it is obvious that a ship is in danger of sinking, but that there is still time in hand before it becomes necessary to abandon ship, coxswain would do well to have some extra gear put in the boat. However, it may always be remembered that more extra gear out in the boat means that there would be that much lesser room available for survivors.

2023 A recommended list of extra gear which may be taken from the ship to the survival craft, if time permits, is given below :

- (a) Blankets
- (b) Tinned milk, milk tablets, fruit, biscuits and sweets
- (c) Note-book, pencil and a water-proof watch
- (d) Torches, batteries and bulbs
- (e) Palm, needles and sail twine
- (f) Ship's pyrotechnics, if unused
- (g) EPIRB's
- (h) Plastic bags and a small pocket radio receiver
- (i) Fog Horn
- (j) Thermal protective aids and immersion suits
- (k) Take extra water, fuel and lubricating oil, three quarter full clean bottle-necked containers or jerry cans, then cork, float and tow them.
- (l) Take a grapnel and line (in a boat only)

Abandoning Ship – Complications :

2024 It must always be remembered that an emergency can never be adequately simulated. There is a distinct difference between drills and real emergency situations. The knowledge and practice acquired during drills is important for handling a real emergency situation. Yet this alone may not be enough. Personnel should be prepared to perform additional tasks in an actual emergency.

2025 If the crewmembers assigned to certain duties are incapacitated, then others would have to perform additional tasks to make up for them. This means that during drills each member should watch the whole team at work in addition to carrying out his own duties.

2026 Absence of lighting and listing of the ship may lead to disorientation which can be prevented if the ship's personnel know by heart their emergency stations and how to get to them.

2027 Damage to their assigned survival craft may force personnel to embark in other craft.

2028 To summarise, complications in abandoning ship may be caused by :

- (a) Some of the survival craft not being capable of being launched.
- (b) Absence of lighting; and
- (c) Absence of personnel assigned to certain duties.

CHAPTER 3 — EVACUATION

3001 The decision to abandon ship is taken after considerable thought and only as a last resort. The ship is the best “survival craft”. Thus in case of any emergency it is a constant endeavour to be on board and tackle the emergency itself. However, as and when it becomes evident that remaining on board would be detrimental to survival and life threatening, the decision for evacuation may be taken. This decision to evacuate is executed by an order from the master to “Abandon Ship”.

3002 **Abandoning ship last resort.** When disaster strikes a ship, the master may be compelled to order the vessel to be abandoned. Since the ship provides all life support systems, any decision to abandon is normally a last resort. Should the vessel be no longer safe because of collision, fire explosion, toxic substance or caprice or any other reason the order to abandon may be given.

3003 **Personal Preparation.** The circumstances will dictate what action should be taken by personnel. In an escalating emergency where abandonment is a likely outcome, warm clothing preferably a thermal suit, covered by an immersion or survival suit is essential. A life jacket should be donned and secured tightly. Once immersed in cold water with a badly secured life jacket, survivors would find the task of re-securing with wet, cold hands extremely difficult if not impossible.

3004 **Prevent Panic.** It is normal practice that the order to abandon ship is passed by word of mouth. Personnel in boats are to be seated and strapped into position. The officer in-charge assumes command of operation within the craft, and persons should remember that launching period is critical, and that the concentration of the officer in charge should not be interrupted except in exceptional circumstances. It is a period of tension and it is within survivor’s own interests to allow persons with designated task to be left alone to get on with the job in hand. Keep alert, and unless you have constructive comment regarding the situation, keep quiet, assist other people inside the craft, especially injured personnel, if you can. Make casualties as comfortable as possible and try to reassure them that everything is going well, even when the situation may appear to be difficult.

3005 **Crew Duties to Passengers.** SOLAS regulations specify that there shall be sufficient number of trained persons on board a ship for mustering and assisting untrained persons. These may be deck officers or certified persons. The muster list shows several duties assigned to member of the crew in relation to passengers in case of emergency. The duties shall include:

- (a) Warning the passengers.
- (b) Seeing that they are suitably clad and have donned their life jacket correctly.
- (c) Assembling passengers at muster stations.
- (d) Keeping order in passengers and on the stairways and generally controlling the movements of the passengers.
- (e) Ensuring that a supply of blankets is taken to the survival craft.

3006 **Crew Duties Launching Survival Craft**. There shall be sufficient number of crew members, who may be deck officers or certified persons, on board for operating the survival craft and launching arrangements required for abandonment by the total number of persons on board. Personnel required on board for the operation of survival craft and implementation of launching arrangements as follows :-

- (a) Bowman.
- (b) Ford Gripes safety pin and painter.
- (c) Brakesman.
- (d) After gripes and safety pins.
- (e) Ladder and help passengers man the boat.
- (f) Stern sheet.

3007 **Master's Order to Abandon Ship**. The order to abandon ship is given directly by the master when disaster strikes a vessel and she is no longer safe due to :

- (a) Collision.
- (b) Fire.
- (c) Explosion etc

NO SHIP IS TO BE ABANDONED, EXCEPT BY ORDER OF THE MASTER.

3008 **Means essential to Survival**. After the ship has been abandoned the following are the essential means required to survive at sea :

- (a) A means of keeping afloat. This is a primary requirement. The aim is to remain afloat with minimal loss of body heat or energy. The means available are life jackets, life rafts and lifeboats.
- (b) A means of keeping warm (appropriate warm clothing). Hypothermia or loss of body heat is the major killer of personnel who have abandoned ship at sea. Water being a good conductor causes the body to lose heat rapidly. The best means are good preparation by donning appropriate warm clothing prior to abandoning ship, including thermal protective aids.
- (c) Nourishment – Drinking water and food. First 24 hours nothing, then issue ½ litre per person per day. Only eat carbo – hydrates such as sweet, glucose etc.
- (d) A means to communicate. This is essential to subsequent location and rescue. The means available are lifeboat radio, EPIRB, pyrotechnics, day light signalling mirror waterproof torch etc.

CHAPTER 4 – SURVIVAL CRAFT AND RESCUE BOATS

4001 A lifeboat shall have enough stability in a seaway and sufficient freeboard when loaded with full complement of persons and equipment.

A lifeboat shall have rigid hulls and shall be capable of maintaining positive stability in an upright position in calm water and with full complement and equipment and holed in any one location below the waterline, assuming no loss of buoyancy material and no other damage.

All lifeboats shall be able to be launched and towed when the ship is making headway of 5 knots in calm water.

A fully loaded lifeboat can be dropped from a height of 3 meters.

Should have enough seating arrangement for the capacity it is supposed to carry, each person weighing 100 kgs.

A lifeboat shall not carry more than 150 persons.

4002 **Buoyancy Tanks**. Buoyancy tanks are situated at the sides of the lifeboat. At least 10% of the volume of the lifeboat is occupied by the buoyancy tank.

4003 **Lowering A Survival Craft OR A Rescue Boat**. The speed at which the survival craft or rescue boat is lowered into the water in a fully loaded condition shall be not less than that obtained from the formula: $S=0.4+(0.02 \times H)$

Where S = Speed of lowering in meters per second and H = Height in meters from davit head to the waterline at the lightest sea – going condition.

Provided that, in case, arrangements shall be made so that the lowering speed in loaded condition does not exceed 1 meter per second. In case of lifeboats in light condition, with the boat fully equipped and manned by one person the speed shall not be less than 75% of the speed in loaded condition.

4004 **Lifeboat Propulsior** : Lifeboat shall be powered by a compression ignition engine. No life boat engine can be used if the fuel used in it has a flash point of 43 degree C or less. The lifeboat engine can either be two stroke or four-stroke type, and can be started either by hand or by power. Power starting can be by using accumulator batteries or hydraulic.

In power starting, normally two independent rechargeable energy sources are provided however, any starting method should be capable of starting engines at 15 degrees C of ambient temperature within two minutes of commencing of starting procedure.

The engine power is transmitted to propeller through gearbox. The gearbox is capable of disengaging the engine as well as engaging in either ahead or astern direction.

The engine on starting should be allowed to run at slow speed, with propeller shaft disengaged. When engine warms up and then engine revs are increased gradually. The

exhaust pipe outlet is located well clear of waterline. The engine, its accessories and gearbox is enclosed in fire retardant casing.

Essential tools such as shifter, screw driver, spanner, cranking levers etc. are kept in lifeboat at all times and should never be removed from lifeboat.

Engine should be capable of operating for not less than 5 minutes after starting from cold, with lifeboat out of water.

A fully loaded lifeboat in calm water has an engine speed of 6 knots and enough fuel for 24 hours. When towing the biggest life raft it makes good a speed of at least 2 knots. Before lowering lifeboat, battery-charging connection should be disconnected, if provided.

Lifeboat engine operation will not interfere with the operation of radio life-saving appliances.

4005. **Markings On A Life Boat.** The name and port of registry of the ship to which the lifeboat belongs shall be marked on each side of the lifeboat bow in block capitals. The dimensions of the lifeboat and the number of persons which it is permitted to accommodate shall be clearly marked. Means of identifying the ship to which the life boat belongs and the number of the life boat shall be marked on the canopy in such a way that they are visible from above.

4006 **Weekly And Monthly Inspections.** Every week survival crafts rescue boats davits and all launching gear should be inspected visually. The lifeboat engine tested for a period of at least three minutes. Rescue boat out motor tested in a drum of water if possible. The emergency alarm must be tested from all points.

Every month all equipment from lifeboats and rescue boats as per the checklist. Boats swung out and lowered to the water level. Fixed radio installations and searchlights examined and tested. Enclosed lifeboats with water spray systems should be tested as per manufacturer instruction. Entries to be made in the logbook.

4007 **On Board Training Is A Must For All New Seaman Joining The Vessel.** As soon as possible not more than two weeks after joining the vessel all new seaman should be taken for a tour around the vessel, (from funnel to tunnel) and all lifesaving and safety equipment should be explained to them.

- (a) Funnel escapes route.
- (b) All flaps and ventilation's.
- (c) The use of survival crafts, rescue boats and life rafts.
- (d) Use of life buoys and life jackets.
- (e) Use of immersion suit and thermal proactive aid.
- (f) Use of EPIRB and SART
- (g) Use of the first aid and Kit.
- (h) Use of the training manuals.

4008 **Fire Protected Lifeboats.** A fire-protected lifeboat when waterborne shall be capable of protecting the number of persons it is permitted to accommodate when subjected to a continuous oil fire that envelopes the lifeboat for a period of not less than 8 minutes.

A life boat which has a water spray system fire-protection system shall comply with the following :-

- (a) Water for the system shall be drawn from the sea by a self-priming motor pump. It shall be possible to turn “on” and “off” the flow of water over the exterior of the lifeboat.
- (b) The seawater intake shall be so arranged as to prevent the intake of flammable liquids from the sea surface. So the suction should be as low as possible.
- (c) The system should so arranged that it can be flushed with fresh water and allowing complete drainage.

4009 **Lifeboat With A Self Contained Air Support System.** A life boat with a self contained air – support system shall be so arranged that, when proceeding with all entrances and openings closed, the air in the lifeboat remains safe and breathable and the engine runs normally for a period of not less than 10 minutes. During the period the atmospheric pressure inside the lifeboat shall never fall below the outside atmospheric pressure nor shall it exceed it by more than 20 mbar. The system shall have visual indicators to indicate the air supply at all times.

4010 **Capacity Of A Lifeboat.**

Number of persons a life boat can carry = length x breadth x depth x 0.6 = 0.283
Length, breadth and depth in meters.
0.6 = is the coefficient of fitness.
0.283 = is the amount of space that one person requires in a lifeboat.

4011. **Boat And Fire Drill Requirement**

Lifeboat drills every week for Passenger ship – Every 15 days for cargo ship. Swing out and lower to water level every month.
Lower into water and manoeuvred in the water every three months.

4012. **Cargo Ship Capacity Of Lifeboat.**

Gravity type davits.

Life boats	200% (100% on each side)
Liferafts	100% (if liferafts in such a position that can be shifted either to port or stbd).

If the life rafts cannot be shifted to either side due to some obstruction on deck then there will be 100% life rafts on either side.

Lifeboats	200% (100% on each side)
Liferafts	200% (100% on each side)
	400% total life saving capacity.

4013. **Passenger Ships Lifeboat Capacity.** Passenger ships engaging on international voyage, which is not a short international voyage (the course is less than 200 miles from any port or place and distance between two destinations is less than 600 miles) shall carry partially enclosed life boats, partially enclosed self righting life boats or totally enclosed lifeboats on each side of such aggregate capacity as well accommodate not less than 50% of the total number of persons on board. The marine director may permit the substitution of life boats by liferaft or equivalent total capacity provided there shall never be less than sufficient lifeboats on each side of the ship to accommodate 37.5% of the total number of persons on board.

In addition, passenger ships shall also carry inflatable liferaft or rigid liferaft of such aggregate capacity as will accommodate at least 25% of the total number of the persons on board.

Passenger ships shall also carry at least one rescue boat at each side of the ship. However, a lifeboat carried onboard may be accepted as a rescue boat provided it complies with the rescue boat regulation. Passenger ships shall also carry at least one launching appliance for liferaft on each side.

4014. **Vessels With Additional Liferafts.** On a vessel where the survival crafts are more than 100 meters away from the forward end of the vessel there will be one liferaft of six persons at the forward end. On a vessel where the survival crafts are more than 100 meters away from the after end of the vessel there will be one liferaft of six persons at the after end.

4015 **Launching Gear For Lifeboats.** Should be lowered by gravity or stored mechanical power independent of ships power supplies capable of being launched by one person should be able to lower against a trim of 10 degrees and a list of upto 20 degree, with the full complement of persons. Also should be able to be lowered when the vessel is making a minimum speed of 5 kts through the water. The person lowering the lifeboat shall be in such a position within the survival craft/rescue boat that the survival craft shall be visible to the person on deck operating the launching mechanism. Lifeboat launching appliance shall be capable of recovering the lifeboat with its crew. It should remain effective under condition of icing.

A minimum factor of safety of 4.5 shall be applied to all davits and winch structural members, and a minimum factor of safety of 6 to falls, suspension chains, links and blocks.

Falls should be of rotation-resistant and corrosion-resistant steel wire rope. Changed if damaged or every 5 years (60 months). To be turned end to end every 2.5 year (30 months).

4016 **Type of Davits :**

- (a) Radial davits
- (b) Luffing davits
- (c) Gravity davits
- (d) Free fall launching davits

(A) **Radial Davits** (Not used now-a-days)

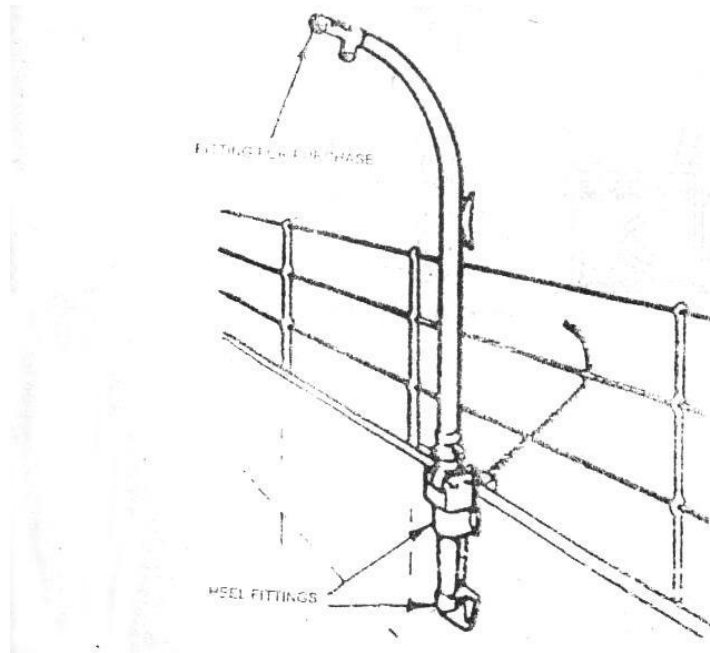

B. **Luffing Davits** (not much in use now a days).

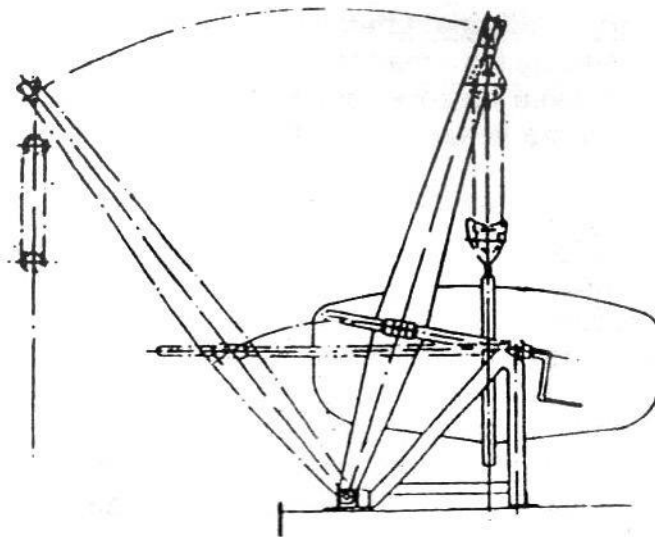

The operation gear of all luffing type davits shall be of sufficient power to ensure that the lifeboats fully equipped and manned with the launching crew, but not loaded with other persons, can be turned out against a list of at least 15 degrees.

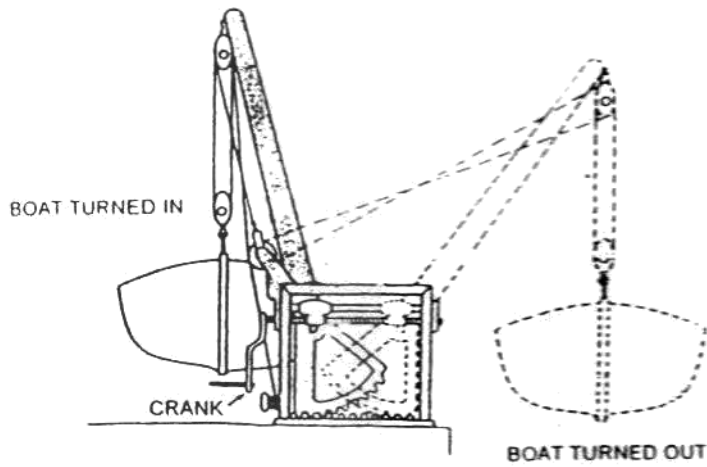

C. Gravity Davits (still in use)

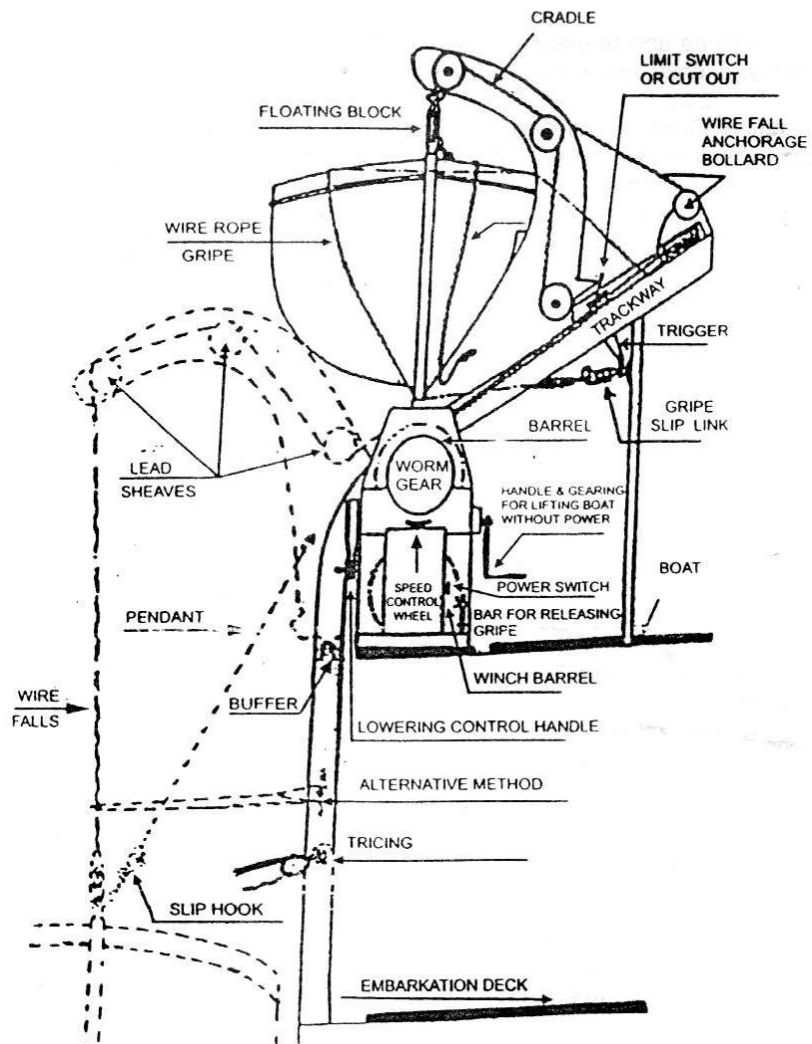

4017 **Abandon Ship Drill** On hearing the alarm all passengers and crew to muster at the muster station (EHQ). They should wear warm clothes and properly dressed with shoes and take their life jacket and immersion suit. They should also drink some water and then report to the muster station. At the muster station they will come to know the type of emergency. They should be aware of the emergency signal and the abandon ship signal specified in the muster list.

Report for stations and prepare for the described duties in the must list. Check that the passenger and crew are suitable dressed. Check that lifejackets are properly donned. Lowering of at least one lifeboat after preparing for launching. Starting and operating the lifeboat engine. Operating of davits for launching life-raft. Realistic drills to be conducted. Life boats to be lowered and tried out in the water at least once every three months. If due to berthing arrangements in port and their trading patterns it is not permitted to launch the life boat on one side the administration may allow the ship not to launch the lifeboat on one side. All such lifeboats shall be lowered at least once every three months and launched at least annually.

Rescue boats which are other than lifeboats which are also rescue boats, shall be launched with their crew and manoeuvred in the water at least once a month. In all cases, this shall be complied with at least once every three months.

If boat launching drills are carried out while the ship is making headway, because of the danger involved, these drills will be carried out in sheltered waters and under the supervision of any experienced officer

Emergency lights for muster and abandon station shall be tested during each drill.

4018 **Lowering A Lifeboat With Gravity Davits In Good Weather / Bad Weather.**

To lower a lifeboat with gravity type davits a minimum of seven person is required. The rest of the crew can be sent get extra water, food, blandest and any other equipments.

4019 **The Five Persons For Lowering The Boat Will be :**

Bowman

- Check plug.
- Check lifeline
- Check boat falls and blocks.
- Pass the toggle painter ford.
- Make fast the tracing pendant.

Ford. Gripe

- Slip the Ford Gripe.
- Remove the ford. Harbour Safety pin.
- Take the painter ford and make fast.
- Stand by to lower the embarkation ladder.

Winch Man

- Remove the canvas cover.
- Check if the shipside is clear.
- Lower the lifeboat when ordered.
- Slip the aft. Gripe.
- Remove the aft. Harbour Safety Pin.
- Stand by to lower the embarkation ladder.

Sternsheet

- Check plug.
- Check lifeline
- Check boat falls and blocks.
- Make fast the tracing pendant.

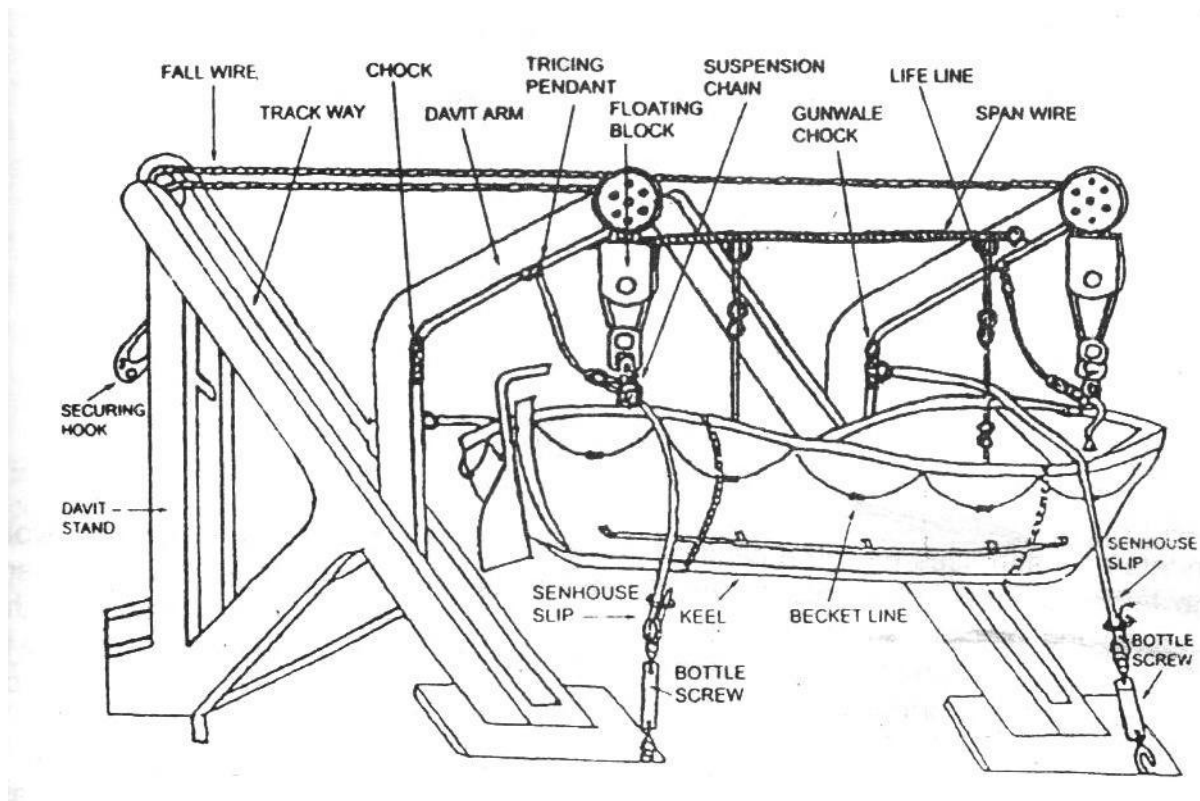

After these five persons have done their jobs they will report to the coxwain/the person incharge. The persons in charge will then report to the bridge. In the mean time the rest of the persons who wee sent to get water, provisions and other things will report back. Then the bridge will give the orders to abandon ship. Now try and board as many persons into the lifeboat only the winch man will stay on board to lower the lifeboat. If the ship has self lowering system then no one is needed to stay on the ship the lifeboat can be lowered from the lifeboat itself.

The lifeboat engine can be started 5 minutes before the lifeboat touches the water. The coxwain will put the tiller to the ship side and as the lifeboat touches the crest the wave the

boat will be unhooked, the bowman will let go the painter and push off from the bows with the help of the boat hook. The engine will be put and the lifeboat will move away from the shipside. This would be done if the weather is good. Clear the shipside by about half to three quarter of a mile as the sinking ship will create suction that could pull the lifeboat under water.

4020. **Lowering A Lifeboat In Bad Weather.**

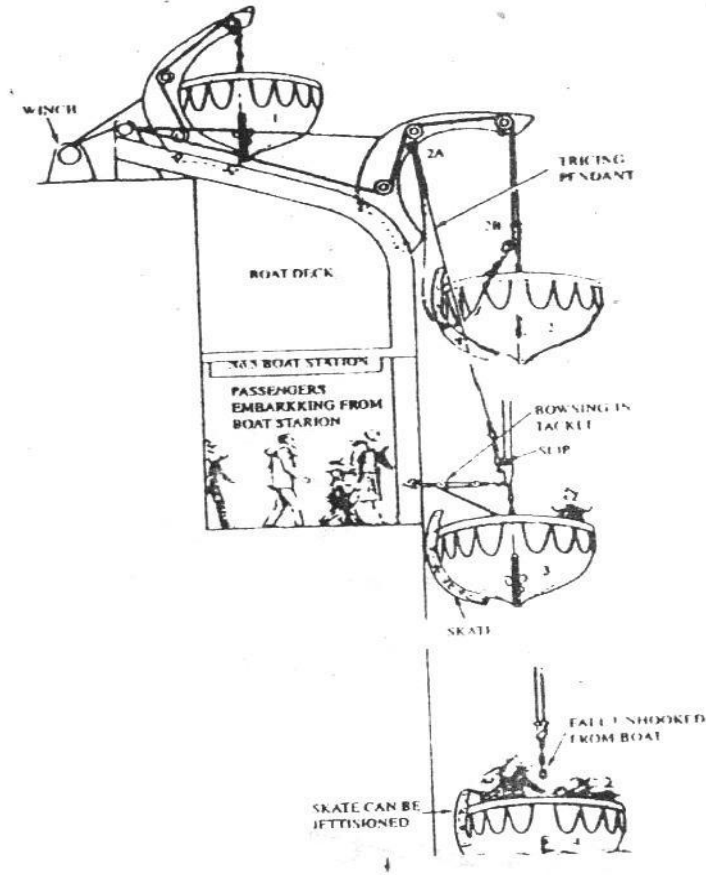

Put fenders or mattresses from the cabins between the shipside and the lifeboat to avoid damage to the lifeboat. The lines to the fall blocks so that as soon as the hooks are disconnected the blocks can be lifted by the lines to avoid injury to the persons in the lifeboat. If the ship is rolling tie a rope round the falls and the rail/staunchness of the ship to avoid the lifeboat from swinging if the ship is rolling. Lower the lifeboat on a crest never on a trough.

The engine speed of a lifeboat is 6 knots and there would be enough fuel for at least 24 hours. While towing the largest liferaft the lifeboats speed should be at least 2 knots.

After the ship sinks marshalling of lifeboats and liferafts and picking up of survivors is done. In the day time one can see the survivors, during the night the whistle on the life jacket use can be used to attract attention and the searchlight will be reflected by the retro-reflector tape.

After picking up survivors then try and stay as close to the position of the sunk ship as possible because all ships and airplanes that will be coming to the rescue will be heading to the position that was given by the ship before it went down. Stop engines and stream the sea-anchor. The sea anchor serves two purposes, it acts as an anchor and reduces the drift; it does not let the lifeboat get broad side to the sea and swell. It keeps the bows into the sea and swell, so that the lifeboat rides the sea and swell and does not capsize.

Although the lifeboat has enough fuel for 24 hours you do not go anywhere but stay there till some ship comes by and rescues you. It could take you days.

4021. **Release Mechanism For Lifeboat On Load Or Off Load System**

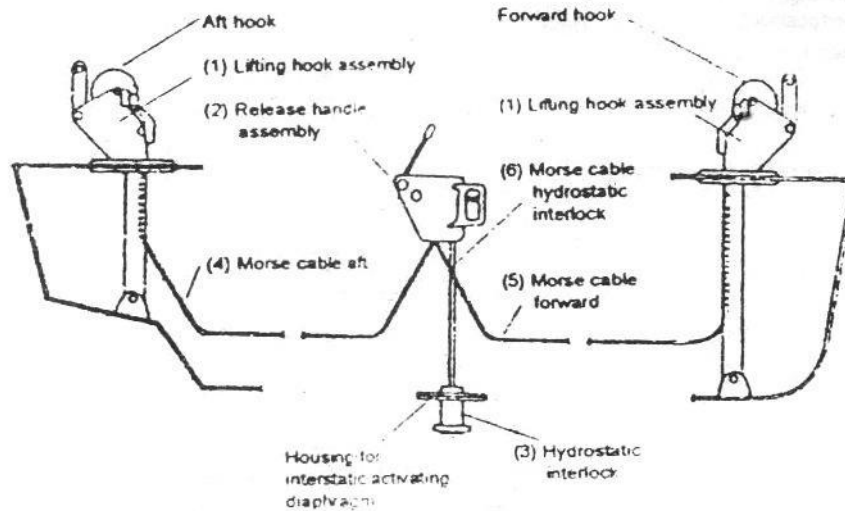

Every lifeboat to be launched by a fall or falls shall be fitted with a released mechanism complying with the following :-

- (a) The mechanism shall be so arranged that all hooks are release simultaneously.
- (b) The mechanism shall have two release capabilities as follows :
 - 1) A normal release capability, which will release the lifeboat when it is waterborne, or when there is no load on the hooks.
 - 2) An on-loads release capability, which will release the lifeboat with a load on the hooks. The release shall be so arranged as to release the lifeboat under any condition of loading from no-loading with the lifeboat waterborne to a load of 1.1 times the total mass of the fully equipped lifeboat loaded with its full complement of persons and equipment. This release capability shall be adequately protected against accidental or premature use.
 - 3) The release control shall be clearly marked in a colour that contrasts with its surroundings.
 - 4) The mechanism shall be designed with a factor of safety of 6 based on the ultimate strength of the materials used, assuming the mass of the lifeboat is equally distributed between the falls.

Every lifeboat except free fall launching lifeboats shall be fitted with a release device to enable the forward painter to be released when under tension.

4022 **Rescue Boat.** Boats designed to rescue person in distress and Marshall survival craft is called a rescue boat.

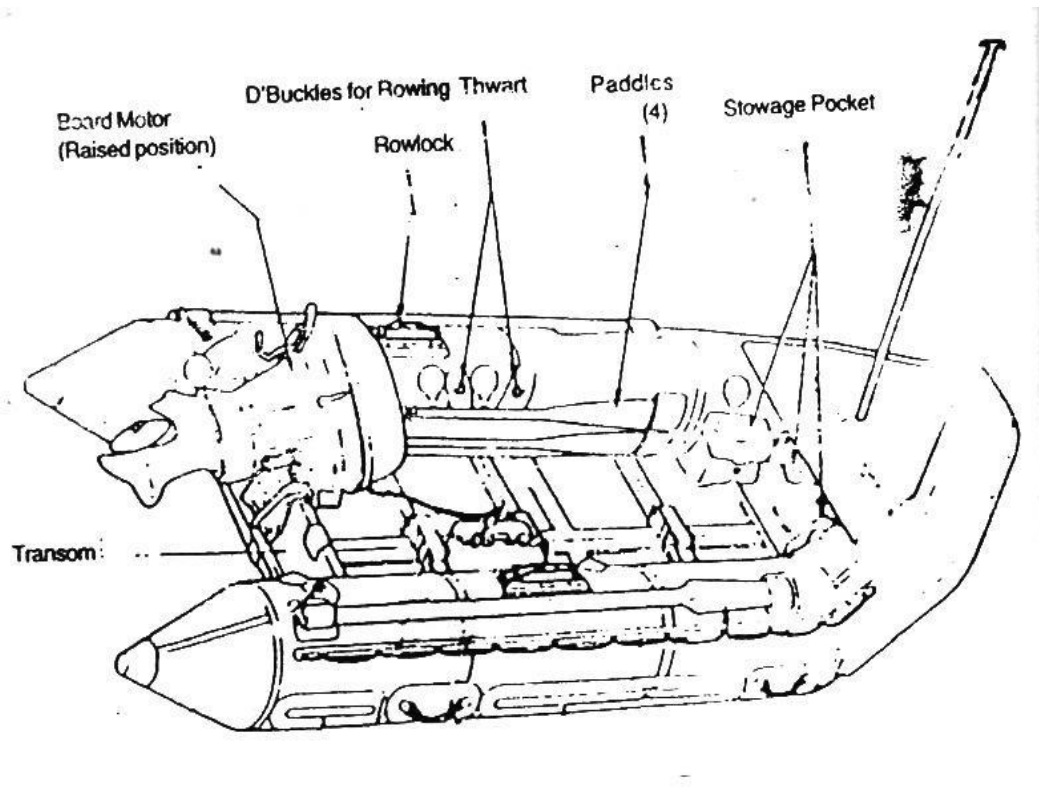

On vessels, which have the free fall launching system from the stern there, will be one more boat, which can be launched and recovered from one side of the vessel (either the stbd or port side). This will be called the rescue boat.

On vessels that have lifeboats with gravity type davits there will be no additional rescue boat. One of the lifeboats can be a rescue boat provided it complies with certain **construction regulations**.

(Vessels constructed from 1st July 1986)

Passenger ships of 500 grt and over must carry at least one rescue boat on each side.

Passenger ships of less than 500 grt and all cargo ships must carry at least one rescue boat.

A rescue boat must be kept in a continuous state of readiness for launching in not more than five minutes. On a cargo vessel, the ships crews have to be able to enter the craft within three minutes from the time boarding instructions are given.

4023. **Rescue Boat Engine.** An operation manual and maintenance manual are available for all outboard engines. Even though operation procedures are almost the same the person using the engine must be conversant with the procedure followed in the operation manual.

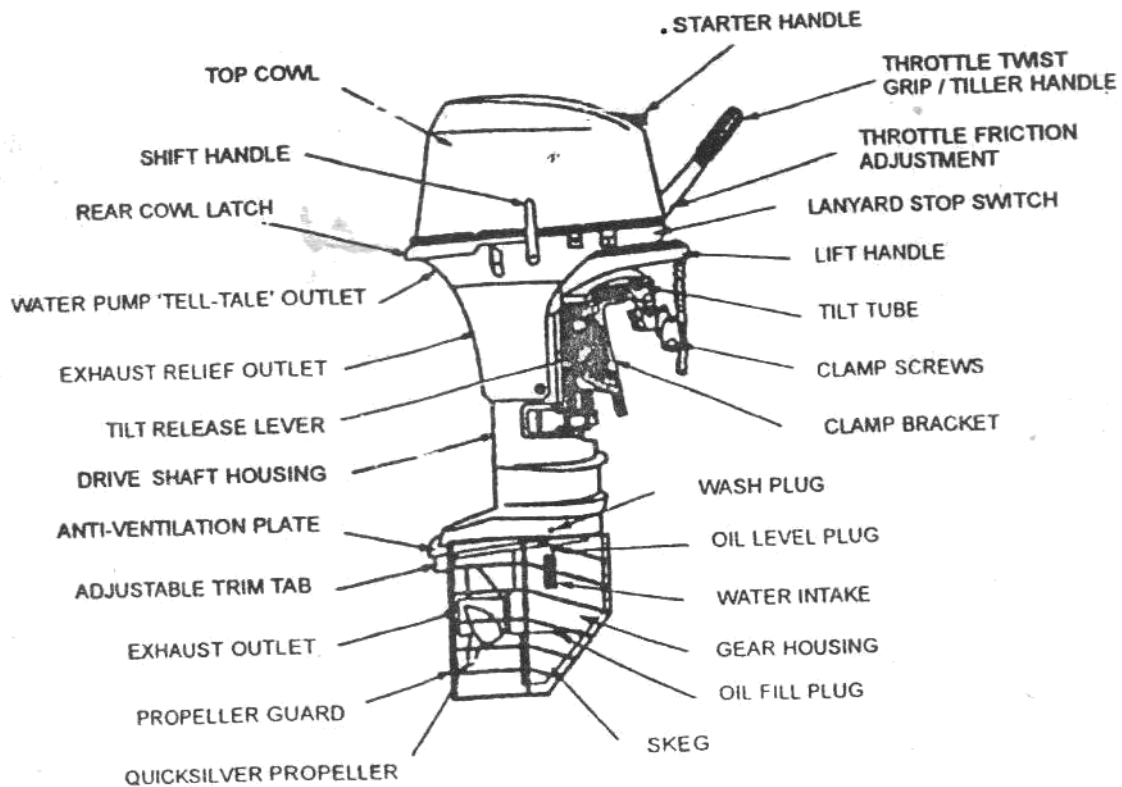

The drive is transmitted to the single propeller by a vertical drive shaft through a gearbox, with one forward, one reverse and a neutral position. The gearshift is sited on the side of the power head. Engine and steering control are effected by a tiller incorporating a speed control twist grip. Fuel, which is a petrol/oil mixture, is carried in a portable tank. Engine starting arrangements are a starter rope wound around the periphery of the engine flywheel. When in use the outboard engine must be firmly clamped to the transom, it must also be secured to the transom by a 6 mm wire presenter stop. When an engine is being shipped or unshipped it must have a safety line.

4024. **Cooling System.** The engine is cooled by circulating water that is drawn up through intakes at the foot of the engine and discharged through an outlet on the propeller hub. There is a telltale discharge on the starboard after side of the engine to indicate if the system is working. The engine must never be run out of the water because it will seize up within a period of a few seconds. The person at the tiller must make frequent checks to ensure that water is running from the telltale discharge. If the flow of the water through the discharge stops, the engine must be stopped immediately.

4025. **Exhaust System.** Exhaust gases from the outboard motor pass through the exhaust tube to the bottom of the exhaust housing, there they mix with the cooling water before leaving the engine. Exhaust and cooling water are discharged together through the propeller hub. An additional exhaust port is sited just below the power head at the rear of the engine. This exhaust prevents a build up of exhaust gases in the engine when the boat is stationary in the water.

4026. **Transmission And Gears.** The engine transmits power to the gearbox through a vertical drive shaft. A bevel pinion on the bottom of the drive shaft, which is in constant mesh with the ahead and astern gear wheels, drives then to rotate continuously while the engine is

running. The required gear is engaged to the propeller drive shaft by moving a dog clutch along splines. Considerable care must be taken not to damage the dog clutch. The engine must be brought down to idling speed before going on to engage the selected gear.

4027. **Cut-Out Switch.** A “Killer cord” hooks over the ignition cut-out switch on the front of the powerhead, during normal operations the switch is in the “Run’ position. One end of the cord hooked over the switch: the other is secured to the leg of the person handling the boat. By tugging on the cord the switch is pulled to the “off” position, the ignition circuit is broken and the engine stops. A spare cord must be readily available.

4028. **Fuel System.** The fuel tank is equipped with fuel line, primer bulb and valves and on the engine a fuel pump and a carburetor. To connect the fuel line, slide the connector on to the male connector on the port side of the powerhead until the locking lever snaps into place: the locking lever should only be pressed into disconnect. Before starting, the carburetor must be primed with fuel by squeezing the priming bulb several times until resistance indicates that pressure has built up. The fuel pump in the outboard motor is not self-priming, but once the engine has been started it will continue drawing in fuel through the valves in the priming bulb.

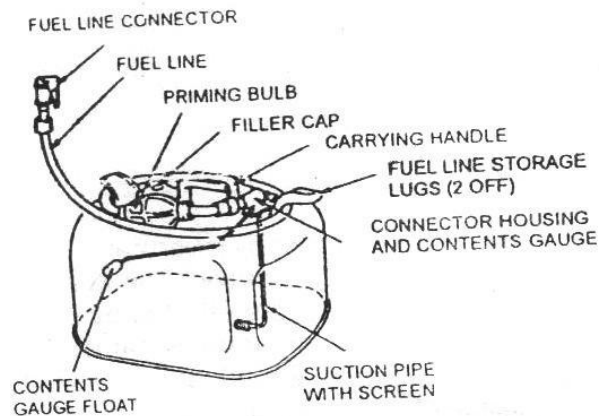

Fuel Tank and Fittings

4029. **Propeller Assemble.** A rubber bust in the hub of the propeller is keyed to a splined drive shaft. This allows the propeller to slip on the shaft to reduce damage if it encounters an underwater obstacle. The propeller can be quickly removed and placed : the securing nut should be screwed up until the holes in the nut line up with the holes in the propeller shaft: the split pin is then inserted and splayed. A propeller guard must be fitted.

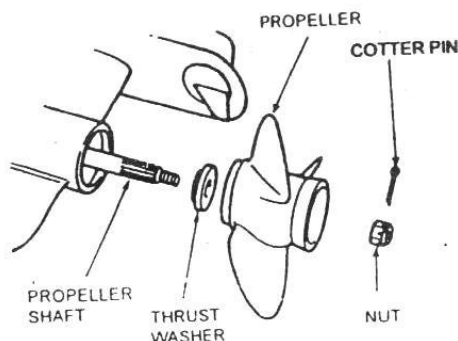

4030. **Stowage Of Rescue Boats.** Rescue boats shall be stowed :-

- 1) In a continuous state of readiness and can be launched in not more than 5 minutes.
- 2) In such a position that it can be launched and recovered easily.
- 3) The rescue boat and launching gear will not interfere with the operation of the survival crafts or any other survival gear.

4031. **Construction Regulations**

Rescue boats may be of either rigid (fibre glass) or inflated construction, or a combination of the two.

The rescue boat must :

- 1) Be not less than 3.8 m and not more than 8.5 m in length.
- 2) Be capable of carrying at least five plus one persons.
- 3) Be capable of towing the largest liferaft carried on the ship in a loaded state at a speed of at least two knots.
- 4) Be capable of manoeuvring at a speed of at least six knots for at least four hours.
- 5) Have a searchlight.
- 6) Have a recovery pendant system to recover the rescue boat.

RESCUE BOAT EQUIPMENT

- 1) A boarding ladder.
- 2) Sufficient buoyant cars or paddies.
- 3) A buoyant bailer.
- 4) A compass in binnacles.
- 5) A sea anchor.
- 6) A painter.
- 7) A towline, not less than 50 m in length.
- 8) A torch with spare batteries and bulbs.
- 9) A whistle.
- 10) A first aid kit.
- 11) Two buoyant rescue quoits with not less than 30 m of line.
- 12) An efficient radar reflector.
- 13) An immersion suit for all the boats crew.
- 14) A boat hook.

- 15) A bucket.
- 16) A knife or hatchet.
- 17) A portable fire extinguisher.

4032. Recovery Pendant For Rescue Boat

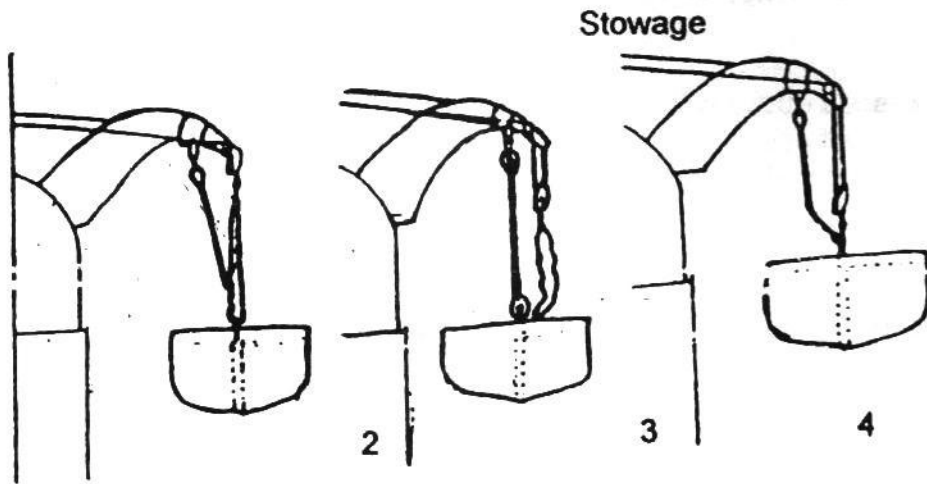
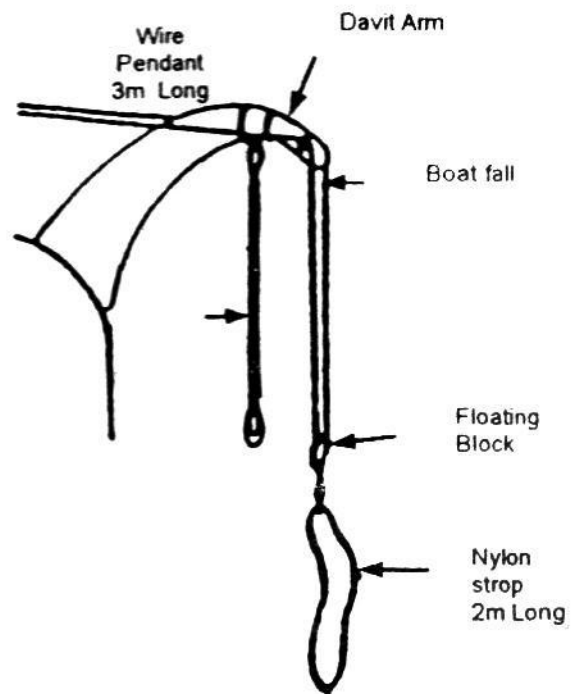
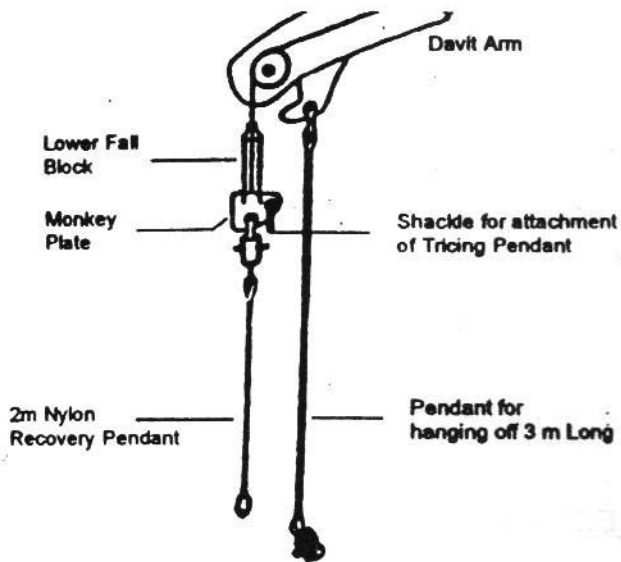

4033. **Liferafts.** There are two types of liferafts which are carried on board ships :-

- a) Inflatable liferafts.
- b) Rigid liferafts.

4034. **Inflatable liferafts.** Inflatable liferafts come in varying capacities from a minimum of 6 to a maximum of 42. General description of an inflatable liferaft is outlined below :

- (a) **Material.** Inflatable liferafts are made from nylon fabric covered on both sides with rubber. The material used for the inflatable hull and the arches is designed for abrasion resistance on the outside and for gas holding properties on the inside, and is usually black/gray in colour. The canopy is normally orange (highly visible) colour.
- (b) **Operating Cord And Painter.** The operating cord is secured firmly to a strong point on the ship. When thrown overboard and stretched to the full length a sharp pull on this cord will fire the firing mechanism of the gas bottle. The same cord then acts as the painter. The painter is to be not less than 15 m, or twice the distance from the stowed position to water line when the vessel is in the lightest sea going condition, whichever is greater.
- (c) **Buoyancy Chambers.** The liferafts is required to have an even number of separate buoyancy compartments, usually two independent of each other. Each chamber must be able to support the liferaft weight by itself. The normal pressure in the life raft is around is 2 lbs. per square inch. If this pressure is exceeded the relief valve will blow.
- (d) **Gas Cylinder.** Inflatable liferafts use carbon dioxide as gas for filling the buoyancy chamber. A little nitrogen is added as anti freeze, which also ensures that the CO₂ is discharged completely.
- (e) **Rain Pocket.** There is a pocket on the canopy provided for collecting rainwater. From this pocket a tube runs into life raft for collecting this water.
- (f) **Lamp.** A lamp is fitted both inside and outside the raft, powered from water activated battery. These batteries can operate for at least 12 hours. The battery can be disconnected when not required.
- (g) **Canopy.** The tent formed by the canopy is doubled skinned. The outer layer is fluorescent orange in colour for easy spotting.
- (h) **Access.** There are usually two openings called the bow and the stern entrances. Each entrance is provided with two flap covers connected to the canopy on the outside and buoyancy chamber on the inside. These covers prevent rain and spray from coming inside the raft, while allowing fresh air to be admitted.
- (i) **Life Line.** Lifeline is bucketed around the outside of the raft, so that the persons in the water can hang on to it. There is also a handline bucketed around the inside of the raft, for the purpose of helping to support the survivors in a seaway.

- (j) **Towing Patch.** A towing patch is fitted on the outside of every life raft. This is used to tow the life raft, attach a sea hanker or to tie two life rafts together.

4035. General Requirements For Construction of Life Rafts

- (a) Every life raft shall be so constructed as to be capable of withstanding exposure for 30 days afloat in all sea conditions.
- (b) When dropped into water from a height of 18 meters the life raft and its equipment shall operate satisfactorily.
- (c) The life raft should be able to withstand repeated jumps on it from a height of at least 4.5 meters above its floor both with and without the canopy erected.
- (d) It should be capable of being towed at a speed of 3 knots in calm water when fully loaded and with one sea anchor streamed.
- (e) The canopy shall comply with the following:
- (i) Provide insulation with two layers of material separated by an air gap or other suitable means.
 - (ii) Interior should be of a colour that does not cause discomfort to the occupants.
 - (iii) Each entrance should be clearly indicated and be provided with efficient adjustable closing arrangements. Life rafts with more than eight men capacity shall have at least two diametrically opposite entrances.
 - (iv) Should admit sufficient air at all times even with entrances closed.
 - (v) Should be provided with at least one viewing port.
 - (vi) Should have means for collecting rainwater.
 - (vii) Should have sufficient headroom for seating all occupants under all parts of the canopy.

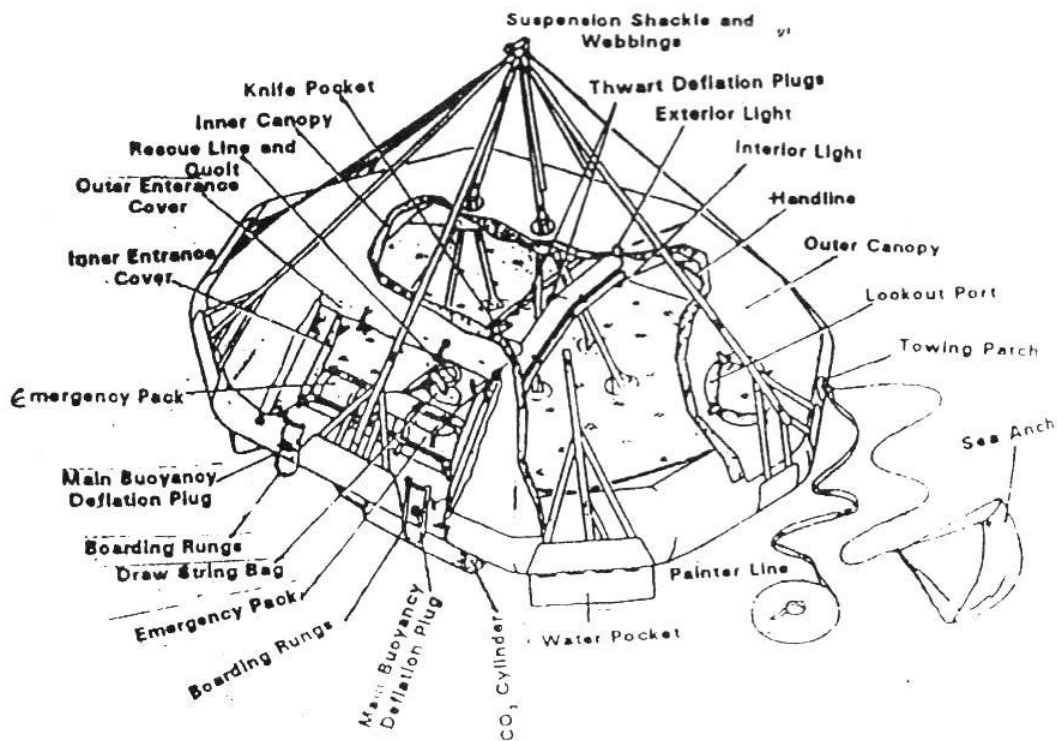

4036. **Life Raft Equipment (SOLAS 'A' PACK).**

- (a) A buoyant rescue quoits at least 30 meters of buoyant line.
- (b) Two sponges, one salt free for collecting condensation.
- (c) One safety knife with a buoyant handle for 12 persons or below and 2 safety knives 13 persons and above.
- (d) One buoyant bailer, for 12 persons or below and two buoyant bailer for 13 persons and above.
- (e) Two sea anchors, one permanently attached. Second sea anchor can be secured in case of rough weather.
- (f) Two buoyant paddles.
- (g) One rust proof graduated drinking vessel.
- (h) One survival instruction manual card.
- (i) Instructions for immediate action.
- (j) A puncture repair kit and a topping up pump or bellows.
- (k) One first aid it in water proof casing.
- (l) One plastic whistle.
- (m) One water proof electric torch.
- (n) One radar reflector or one (SART).
- (o) One day light signalling mirror or heliograph.
- (p) One set of fishing tackle.
- (q) One set of life saving signals.
- (r) Six anti sea sickness tables and sea sickness bag for each person.
- (s) Thermal protective aids sufficient for 10% of carrying capacity of the raft or minimum of two.
- (t) Six hand flares.
- (u) Four buoyant parachutes.
- (v) Two buoyant smoke signals.
- (w) A food ration totaling not less than 10,000 kJ for each person.
- (x) Water 1.5 litre, per person of which ½ litres may be replaced by desalting apparatus in 2 days.
- (y) Three tin openers.

Launching of Life Rafts

4037. The general instructions with regard to launch of life rafts are as follows :

- (a) Remove all obstacles such as railings and soon.

- (b) Rig the boarding ladder.
- (c) Ensure painter is secured to a strong point. If raft is being brought to a launching position ensure painter is secured to a strong point on the ship prior to the launch.
- (d) Throw the life raft overboard.
- (e) Pull all the slack of the painter and give a hard tug or pull. The life raft inflates within 20 to 30 seconds.
- (f) If the life raft inflates upside down, it can be righted by one or two persons facing windward and standing on the gas cylinder. As the life raft frightens the persons quickly swim away.

4038. **Rigid Life Rafts.** All rigid liferafts shall comply with the general requirements specified by the regulations regarding liferafts. The buoyancy of the rigid liferafts shall be provided by approved inherently buoyant material placed as near as possible to the periphery of the liferaft. The buoyant material shall be fire retardant or be protected with fire retardant covering

The floor of the raft shall prevent the ingress of water and shall effectively support the occupants out of the water and insulate them from the cold, the stability being such that it is capable of operating safely whichever way up it is floating. It must be either self-righting or readily righted in a seaway and in calm water by one person. Once loaded with its full complement of persons and equipment it must be possible to tow the raft in calm water at a speed of upto 3 knots.

4039. **Float Free Arrangement for Life Raft.** The float free arrangement for life raft consists of the following :

- (a) Painter System
- (b) Weak Link
- (c) Hydrostatic Release Unit.

4040. **Painter System.** The life raft painter system provides a connection between the ship and the life raft and is so arranged as to ensure that the life raft when released and, in the case of an inflatable life raft, inflated is not dragged under by the sinking ship. The breaking strength of the painter system, with the exception of the weak link arrangement shall be not less than 10.0 KN for rafts carrying nine persons or more and not less than 7.5 KN for other liferafts.

4041. **Weak Link.** The weak link forms the link between the painter system and the ship. It should be of sufficient strength to permit the inflation of the liferaft. It should have a breaking strain of 2.2 ± 0.4 KN.

4042. **Hydrostatic Release Units.** It operates in such a manner as to allow the liferaft to be released from the ship when at a depth of 4 m under water. It should not release the raft when seas wash over the unit and they should be fitted with drain to prevent water accumulation inside the hydrostatic chamber. Release unit should be constructed of compatible materials so as to prevent malfunction of the unit. Galvanising or other forms of metallic coating on parts of the hydrostatic release unit shall not be accepted. It should be permanently marked on the

exterior with its type and serial number. Either a document or identification place stating the date of manufacture, type and serial number will be provided.

Any part connected to the painter system shall have strength of not less than that required for the painter.

The mariner should note that where a survival craft requires a launching appliance and is also designed to float free, the float free release of the survival craft from its stowed position should be automatic.

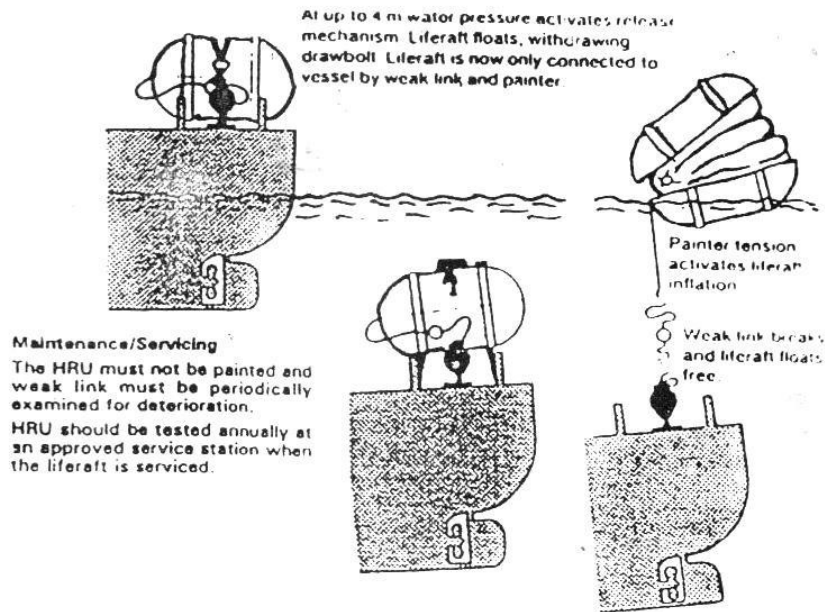

4043. Rescue Boats.

Number Carried.

- (a) Passenger Vessels less than 500 tons gross : At least one rescue boat.
- (b) Passenger Vessels of 500 tons gross or more : At least one rescue boat on each side.
- (c) Cargo Vessels : At least one rescue boat.

4044. General Requirements of Rescue Boats. The requirements which allow a lifeboat to be classed as a rescue boats are :

- (a) Rescue boats may be of either rigid or inflated construction or a combination of both.
- (b) Not less than 3.8 m and not more than 8.5 m in length. Capable of carrying at least five seated persons and a person lying down.

- (c) Rescue boats which are a combination of rigid and inflated construction shall comply with the appropriate requirements of the regulations affecting rescue boats to the satisfaction of the Administration.
- (d) Unless the rescue boat has adequate sheer, it shall be provided with a bow cover extending for not less than 15% of its length.

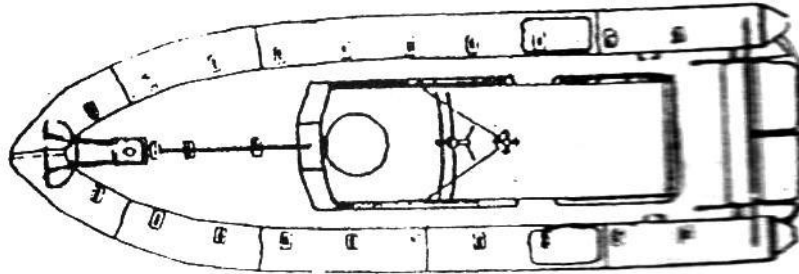

Rescue Boat

- (e) Rescue boats shall be capable of manoeuvring at speeds upto 6 knots and maintaining that speed for a period of at least 4 hours.
- (f) Rescue boats shall have sufficient mobility and manoeuvrability in a seaway to enable persons to be retrieved from the water, marshal liferafts and tow the largest liferaft carried on the ship with its full complement of person and equipment or its equivalent at a speed of at least 2 knots.
- (g) Arrangements for towing shall be permanently fitted in rescue boats and shall be sufficiently strong to marshal or two liferafts as required above.
- (h) A rescue boat shall be fitted with an inboard engine or outboard motor. If it is fitted with an outboard motor, the rudder and the tiller may form part of the engine. Notwithstanding the regulation regarding the flash point of fuel of 43^oC or less, outboard engines with an approved fuel system may be fitted in rescue boats provided the fuel tanks are specially protected against fire and explosion.
- (i) The rescue boat shall be provided with weather tight stowage for small item of equipment.

CHAPTER 5 – PERSONAL LIFE SAVING APPLIANCES

Lifebuoy

5001 **General Requirements.** Every lifebuoy shall :

- (a) Have an outer diameter of not more than 800 mm and inner diameter of not less than 400 mm.
- (b) Be constructed of inherent buoyant material.
- (c) Be capable of supporting at least 14.5 kg. of iron in water for 24 hrs.
- (d) Weigh not less than 2.5 kg.
- (e) Not sustain burning, or continue melting after being totally enveloped in fire for 2s.
- (f) Be able to withstand a drop from its stowed position, or, from a height of 30 m, whichever is greater.
- (g) When fitted to operate quick release arrangement for self activated smoke signals and self igniting lights, have a mass sufficient to operate the quick release arrangement or 4 kg. whichever is greater.
- (h) Have a grabline not less than 9.5 mm in diameter and not less than four times the outer diameter of the buoy in length. The grabline shall be secured at four equidistant points around the circumference of the buoy to form four loops.

5002. **Distribution of Lifebuoy over the ship.** Lifebuoy are distributed over the ship as follows:

- (a) Lifebuoy shall be so distributed as to be readily available on both sides of the ship and as far as practicable on all open decks extending on the ship's side. At least one to be placed in the vicinity of the stern.
- (b) Lifebuoy should be stowed so as to be capable of being cast loose and not permanently secured in any way.

5003. **Requirements For Additional Equipment Attached To Lifebuoy.**

- (a) At least one lifebuoy on each side of the vessel should be fitted with a buoyant lifeline, equal in length to not less than twice the height at which it is stowed above the water-line in the highest seagoing condition or 30 meters, whichever is greater.
- (b) Not less than one half of the total number of lifebuoy shall be provided with self-igniting lights and not less than two of these shall also be provided with self activating smoke signals and be capable of quick release from the navigating bridge. These lifebuoy should be equally distributed on either side of the ship and should not be the lifebuoy previously stated with buoyant lines.

- (c) Self-igniting lights on lifebuoys of tankers shall be of an electric battery type.
- (d) Each life buoy shall be marked in block capitals of the Roman alphabet with name and port of registry of the ship on which it is carried.

Life Jackets

5004 **General Requirements.** Lifejackets shall:

- (a) So constructed that :
 - (i) After demonstration, can be worn within 1 min without assistance.
 - (ii) Either capable of being worn inside out or clearly capable of being worn in only one way.
 - (iii) Be comfortable to wear.
 - (iv) Allow the wearer to jump from a height of 4.5m into water without dislodging or damaging the life jacket.
- (b) Have sufficient buoyancy and stability in calm fresh water to:
 - (i) Lift the mouth of an unconscious or exhausted person not less than 120 mm clear of the water with the body inclined backwards at an angle of not less than 20° and not more than 50° from the vertical position.
 - (ii) Turn the body of an unconscious person in the water from any position to one where the mouth is clear of the water in not more than 5s.
- (c) Have sufficient buoyancy, which is not reduced by more than 5% after 24 hrs. submersion in fresh water.
- (d) Allow the person wearing it to swim a short distance and to board a survival craft.
- (e) Be fitted with a whistle firmly secured by a cord.



1
Place the Life Jacket over the head & be collar tapes firmly.



2
Cross the body tapes (Large tapes) behind & bring them to the front



3
Tie the body tapes at the front firmly.



4
Life jacket is now ready for use

Correct Donning of Lifejacket.

5005. **Life Jackets On Board Passenger Ship.** A life jacket shall be provided for every person on board the ship and in addition:

- (a) A number of lifejacket suitable for children equal to at least 10% of the number of passengers onboard shall be provided or such greater number as may be required to provide a life jacket for each child.
- (b) Every passenger ship shall carry additional life jackets for not less than 5% of the total number of person on board these life jackets being stowed in conspicuous places on deck or at muster stations.

5006 **Life Jackets On Board Cargo Ship.** A life jacket shall be provided for every person on board ship and in addition life jackets for 25% of the persons on board. Sufficient number of life jackets shall be carried for person on watch and for use at remotely located survival craft station.

5007. **Lifejacket Buoyancy.**

- (a) Lifejackets buoyancy may be achieved by packing with buoyant material.
- (c) A lifejacket, which depends on inflation for buoyancy, shall have not less than two separate compartments and comply with regulation for fixed buoyancy type lifejackets.

5008. **Lifejacket Lights.** Life jacket lights shall:-

- (a) Have a luminous intensity of not less than 0.75 cd.
- (b) Have a source of energy capable of providing a luminous intensity of 0.75 cd for a period of at least 8 hours.
- (c) Be visible over as great a segment of the upper hemisphere as is practicable when attached to a lifejacket.
- (d) If the light of the lifejacket is a flashing light it shall in addition:
 - (i) Be provided with a manually operated switch.
 - (ii) Not be fitted with a lens or reflector to concentrate the beam.
 - (iii) Flash at a rate of not less than 50 flashes per minute with a luminous intensity of at least 0.75 cd.

Immersion Suits

5009. **Construction.** The immersion suit shall be constructed with water proof materials such that:

- (a) It can be unpacked and donned without assistance within 2 minutes, taking into account any associated clothing and a lifejacket of the immersion suit is to be worn in conjunction with a lifejacket.

- (b) It will not sustain burning or continue melting after being totally enveloped in a fire for a two seconds period.
 - (c) It will cover the whole body with the exception of the face. Hand shall also be covered unless permanently attached gloves are provided.
 - (b) Be provided with arrangements to minimise or reduce free air in the legs of the suit.
5010. An immersion suit of an appropriate size complying with the regulation shall be provided for every person arranged to crew the rescue boat.
- 5011 On passenger and cargo ships with non-enclosed lifeboats at least three immersion suits shall be carried for each lifeboat.



Immersion Suit

Thermal Protective Aids.

5012 **Purpose.** The main purpose of a thermal protective aid is to reduce both the convective and evaporative heat losses from the wearer's body.

5013 **Requirements.**

- (a) It should cover the whole body of a person wearing a life jacket with the exception of the face. Hands shall also be provided unless permanently attached gloves are provided.
- (b) It should be capable of being unpacked and easily donned without assistance in a survival craft or rescue boat.

- (c) It should permit the wearer to remove it in water in not more than 2 minutes if it impairs the ability to swim.
- (d) The thermal protective aid shall function properly in air temperature from -30°C to $+20^{\circ}\text{C}$.

5014. **Numbers to be carried.**

- (a) **Passenger Ships.** Passenger ships shall carry for each lifeboat on the ship at least one thermal protective aid for every person to be accommodated in the lifeboat and not provided with an immersion suit. This is not applicable for persons accommodated in totally or partially enclosed lifeboats, or if the ship is engaged in a voyage in warm climates.
- (b) **Cargo Ships.** Cargo ships shall carry instead of an immersion suit, one thermal protective aid for every person on board in addition to as required by other regulations. These are not required however if the ship has totally enclosed lifeboats sufficient to carry all persons on board on each side or capable of being launched by free fall from the stern. The exemption is also available if the ship is engaged in voyages in warm climates only.

CHAPTER 6 – SURVIVAL AT SEA

6001 Any person involved in an emergency should try to remain dry. It is known that the body loses its heat twenty six times faster when immersed in water than when kept in a dry environment. For this reason a waterproof suit must be considered extremely desirable for survival. However, for persons finding themselves in water, the following actions are recommended :

- (a) Avoid Unnecessary Swimming. This will only use up valuable energy and increase the body's heat loss to surrounding water.
- (b) Float on the Surface in a Help Position. With the knees clasped up against the chest. This position conserves body heat.
- (c) Try to keep your morale up, and keep the will to survive.
- (d) To avoid panic action.
- (e) As soon as possible after the survival crafts are launched, tie all the survival crafts together congregate in one place far away from the ship. The motor lifeboat may be used to escort survival and other crafts, and to search for survivors.

6002. Once the above procedures are done, the survivors must stay in one place and protect themselves from the environment that is heat and cold. Follow the survival at sea principles laid down for prolonging life under survival conditions.

Dangers To Survivors

6003 Effect of Temperature

- (a) Heat Stroke. A serious condition where the body temperature rises above the normal to 40°C or more. It is caused by prolonged exposure to very hot or very humid conditions. The symptoms are a hot, dry skin, with a rapid pulse rate. The patient may appear flushed and could experience some confusion. Unconsciousness may follow.
- (b) Sun Stroke. Sunstroke can occur when there is a hot sun with high temperature and the absence of wind. The patient gets headache dizziness and feels hot. Sunstroke may some times be fatal.
- (c) Cold and Hypothermia. The majority of deaths are caused by hypothermia during and after the shipwrecks. It means loss of core body temperature. The symptoms of hypothermia include shivering, semi-consciousness, and loss of muscle control or fully unconscious collapse. The treatment is to cover the body by blankets or by thermal protective aids. Never massage, do not give liquid.

- (d) **Effects of Seasickness.** The most seasoned seaman will get seasickness in survival crafts. This results in the loss of body fluids. There is no means to recover it back, as we do not have extra water in survival craft, so it is advisable that as soon as people board the survival craft, seasickness tablets should be given to every person.
- (e) **Lack of Body Fluids.** Failure to maintain body fluids correctly can cause dehydration in the survival craft.
- (f) **Drinking Sea Water.** Avoid drinking seawater. It causes kidney malfunction and result in collapse at sea.
- (g) **Fire or Oil On Water.** Most modern fire protected lifeboats must protect the occupants from the effects of a continuous oil fire that envelope the boat for a period of not less than 8 minutes. Protection to the hull is normally provided by means of a water spray system.
- (h) **Sharks.** As per the new requirements, survival craft must carry shark repellent so that we can repulse shark attack. The shark repellent can be a chemical, which can be sprayed over the water, or it could be applied on the body.

6004 **Clearing Away From The Ship.** Immediately after lowering and boarding the survival craft, measures should be taken to clear the vessel as quickly as possible. The danger of being struck from below by surfacing wreckage is greater than that from the suction caused by the ship sinking. Clearing away may be done by means of oars, paddles or being towed by motor boat. After clearing away, all craft must keep at a safe distance from the ship.

Immediate Action After Entering Survival Craft.

6005. **Lifeboat.**

- (a) **Get away from sinking or burning ship.**
 - let go toggle painter.
 - Manoeuvre or drift to safe distance from ship.
 - Rig radar reflector.
- (b) **Look for and gather survivors.**
 - Manoeuvre and use buoyant lifelines to reach persons in water.
 - Use torch or search light at night.
 - Look for retro-reflective tapes on other life saving appliances and look for liferaft and life jacket lights.
 - Listen for whistles.
- (c) **Join other survival craft.**
 - Use motor boats to retrieve drifting life rafts and secure them to other lifeboats and liferafts.
 - Use sea anchor.

- (d) Check correct functioning of the lifeboat.
 - Check for damage, leaks, and build up of water.
- (e) Commence measures for protection and survival.
 - Rig lifeboat exposure covers.
 - Give first aid to injured.
 - Take action against seasickness.
- (f) Read Survival Manual.

6006 **Inflatable Liferrafts.**

- (a) Get away from sinking or burning ship.
 - Hold on to or hook arms through headlights inside raft (especially in rough weather).
 - Cut painter as far from raft as possible.
 - Manoeuvre or drift to as safe distance from ship.
 - Stream sea anchor or drogues.
 - Rig radar reflector.
- (b) Look for and gather other survivors.
 - use rescue quoit and line to pull survivors to raft.
 - use torch at night.
 - Look for retro reflective tapes on other appliances and look for lifejacket lights.
 - Listen for whistles.
- (c) Check proper functioning of the liferaft.
 - Check for leaks and damages.
 - Plug leaks with leak stoppers from equipment bag.
 - Top up buoyancy chambers and if necessary with pump or bellows.
- (d) Join other rafts if possible.
 - Secure rafts together with remains of painter allowing distance between rafts for movements in a seaway.

6007 **Protective Measures.**

- (a) **Heat Stroke.** To treat heat stroke, remove all the patients clothing and endeavour to keep the body cool. Wrap in a cold sheet and or sponge the body with cold water and keep cooling the body till the temperature starts to fall. Place the casualty in a recovery position and cover with a dry cloth or sheet.

- (b) **Sun Stroke.** Is the common name for conditions that results from overheating the body. Sunstroke in a form of heat stroke caused by being exposed to the sun in tropical area for too long a time skin surface should be protected by suitable clothing.
- (c) **Exposure.** Exposure is a cause of death, after abandoning the vessel, seaman should ensure that body heat is not lost by exposure. Person should take off protective clothing, even if wet, while the survival craft. No person should enter the water from the survival craft as this may lead to exposure.

6008. **Effect of Seasickness.** Seasickness is the main cause of dehydration at sea in the survival craft. So it is important to issue seasickness tablets to every person soon after entering survival craft.

6009 **Food and Water.** Do not issue any food or water for the first 14 hours except to a person, who is sick or injured, as there is amply moisture in body. After 24 hours, issue ½ litre of water per person per day. Effort should be made to preserve the moisture in the body by avoiding perspiration. it is possible to survive upto 14 days or more without water. Survival craft rations consist of non-thirst provoking food.

6010. **Measures of Survival in Case of Burning Oil (Sea) Surface.**

- (a) Evacuation, if by sea, will probably be by rigid survival craft. Fire on ships and platforms, which have spread beyond containment, will probably be accompanied by explosions of greater or lesser degree. The presence of burning oil surface is a distinct possibility, and survival craft should be battened down and enclosed. A fire protected survival craft, when waterborne shall be capable of protecting the number of persons it is permitted to accommodate when subjected to continuous oil fire that envelopes survival craft for a period of not less than 8 minutes.
- (b) A survival craft with a water spray system shall complete the following :
 - (i) Water for the system shall be drawn from the sea by self-priming motor pump. It shall turn on and turn off the flow of water over the outer hull.
 - (ii) The sea water intake shall be so arranged as to prevent the intake of flammable liquid from the sea surface.
 - (iii) The system shall be arranged for flushing with fresh water and allowing complete drainage.

6011 **Means of survival in shark infested waters.** Survivors are advised :

- (a) Never swim or dive alone.
- (b) Never swim or dive with an open wound, which attracts shark.
- (c) Swim as smoothly as possible, because thrashing movements might attract the shark. The survivors are better protected if they can remain inside a plastic bag.

6012. **Sea Anchor (Drogues).** Two sea anchors (drogues) are provided for each liferaft. Each should be fitted with a shock absorbent painter and designed with swivels at each end of the line to prevent fouling. The purpose of the drogue is to reduce the drift route of the life raft and to reduce the rise of life raft and avoid capsizing. Keeping this in mind, one of the sea anchor should be permanently secured so that it can be easily deployed following inflation of the life raft. It should be in such a manner that the life raft is oriented to the wind in a stable manner. It should always be employed when engaging in helicopter rescue operation or in beaching the life raft.

6013 **Lookout.** A watch system should be organised, giving some duty to each occupant of a survival craft. Having something to do or to be responsible as it improves the morale of individual survivors and of the group in general. A constant lookout should be maintained to keep watch all round the horizon. The lookout must be instructed to listen as well as watch. They should be alert for sign of ships, aircraft, land, dangers and rain showers in the vicinity, which may provide an opportunity to supplement the water rate. On making any sighting the lookout should inform the person in charge of the craft before doing anything.

6014 Morale. When survivors are in the survival craft the in charge should raise the morale of the persons who are in the survival craft by keeping the people and their mind busy by a good routine and discipline maintained at the outset of the situation. A water system to be brought into operation. The survivors should communicate their location by using emergency transmitter. This should be activated as soon as practicable. The lookout should be aware of the position of pyrotechnics and how to use instructions being read well before they actually need to be used. Getting people to read the instructions on equipment and designing various job functions are the ways in which the hopes of the survivors are kept alive. Morale is maintained and will to survive is not lost.

6015 **Survival in Water.** Any person involved in an emergency should strive to remain alive. It is known that the body loses its heat twenty six times higher when immersed in water than when kept in a dry environment. For this reason a waterproof suit must be considered extremely essential for survival. However, for persons finding themselves in water, the following actions are recommended :

- (a) **Avoid unnecessary swimming.** This will only use up valuable energy and increase the body's heat loss to surrounding water.
- (b) **Float on the surface in a HELP** (Heat Escape Lessening Posture) position with the knees clasped up against the chest. This position conserves body heat.
- (c) **Secure the face visor of your lifejacket if attached.** Failing this, protect your airways against breaking seas by using your hands to forma face bar.
- (d) **If there is more than one person, group together.** There is safety in number as you are making a larger target when grouped on the surface. If survivors form a circle group, free flowing water is restricted in the centre of the circle and the loss of heat is reduced. Casualties can also be kept warmer by being place in the middle of the circle and supported by the others. Lifelines fitted to certain suits can also be employed to link survivors together

- (e) **Keep your morale up.** Keep the will to survive.
- (f) **Maintain as much of your body out of the water as possible.** throughout and avoid panic actions.



HELP Posture

CHAPTER 7 – HELICOPTER ASSISTANCE

7001 The primary role of the Search and Rescue (SAR) helicopter is to save lives of persons in distress. Helicopters are equipped with a hydraulic rescue winch, which is controlled either by the pilot or a winch operator. The helicopter that is mostly used for helicopter rescue is the 'SEAKING' it has a capacity of about 15/20 persons and has a flying time of about 500 miles (200 miles off shore, 200 miles to go back to base and 100 miles to search). Hence there should be no necessary delay at the scene of rescue. Explain to each one their duties the prior to the Helicopter is arrival.

Helicopter rescue can be from a ship in distress, a lifeboat, a life raft and from the sea. Helicopter can also be used for other various services such as change of crew/passengers, supply of stores/provisions and supply of repair items. In such cases, proper and complete details must be communicated to the helicopter operator through the Agents, giving at least 24 hrs. prior notice.

7002 **Ship Board Safety Check List : Helicopter Operations.**

- (a) Have all loose objects within and adjacent to the operating area been secured or removed ?
- (b) Have all aerials, standing or running gear above and in the vicinity of the operating area been lowered/secured ?
- (c) Has a pennant or windsock been hoisted where it can be clearly seen by the helicopter pilot ?
- (d) Has the officer of the watch been consulted about the ship's readiness ?
- (e) Does the leader of the deck party have a portable radio transceiver (walkie-talkie) for communicating with the bridge ?
- (f) Are fire pumps running is there adequate pressure on deck ?
- (g) Are fire hoses ready (in the vicinity of the operating area) ?
- (h) Are foam hoses, monitors and portable foam equipment ready ?
- (i) Has a rescue party been detailed ?
- (j) Are the following available and handy ?

Large Axe; Crowbar; Wire Cutter, Red Emergency Signal Torch; First Aid Equipment; Stretcher.
- (k) Has the correct lighting (including special navigational lights) been switched on prior to night operations ?

- (l) Is the deck party ready, wearing brightly coloured tabards (waistcoats) and protective helmets, and are all passengers clear of the operating area.
- (m) Has the hook handler been equipped with helmet, strong rubber gloves and rubber soled shoes ?
- (n) Is access to and engross from the operating area clear ?

Landing on

- (q) Is the operating area free of heavy spray of seas on deck ?
- (r) Have side rails and, where necessary, awnings, stanchions and other obstructions been lowered or remove.
- (s) Where applicable, have portable pipes been removed and have the remaining apex ends been blanked off.
- (t) Are rope messengers to hand for securing the helicopter, if necessary (Note : only the helicopter pilot may decide whether or not to secure the helicopter).
- (u) Have all personnel been warned to keep clear of rotors and exhausts.

Special precautions for Tankers

- (v) Ships not fitted with an inert gas system: has pressure been released from tanks with thirty (30) minutes of commencement of helicopter operations.
- (w) Ships fitted with an inert Gas System : has pressure in cargo tanks been reduced to slight positive pressure.
- (x) All tankers : have all tank openings been secured following venting operations.

Special precautions for Bulk / Combination carrier

- (y) Has surface ventilation to dry bulk cargoes ceased, and have all hatch openings been fully battened down prior to helicopter operations.

Special precautions for Gas Carriers

- (z) Have all precautions have been taken to prevent vapour emission on deck.

Upon Completion of Check of List, Entry to be made thereof in Vessel's Logbook.

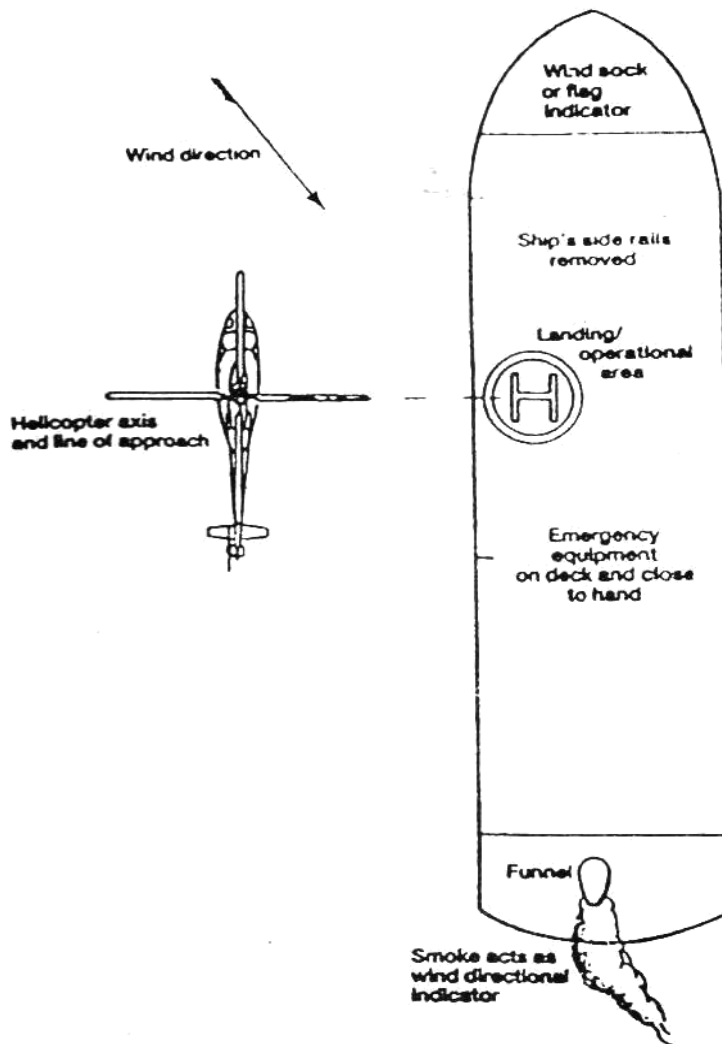

Ship's Deck Plan of Helicopter Operation

Communicating with the Helicopter

7003. **Visual Signals to Helicopter.** The officer in charge will be responsible for signalling the helicopter. The following visual signals should be used :

Forward. Signal given to helicopter pilot to indicate that vessel is ready and the helicopter may approach. (Arms repeated moved upward and backward , beckoning onward).

Finishing Operations. Signal given to helicopter pilot to indicate operations finished. (Arms repeatedly crossed above the head).

7004. **Communications Equipment.** The helicopter must be fitted with a marine VHF FM radio able to transmit and receive on at least channel 16 and two other simple working frequencies. Unless other arrangements have been agreed in advance, the ship should set watch on VHF Channel 16 for the arrival of the helicopter.

7005 **Helo Operations Area.** To make for safe landing as winching operations, it is advisable that any part of the shipside rail within the manoeuvring zone is removed or collapsed without obstructing the clear zone. The section of the ship side rail should be at least as long as the diameter of the clear zone. Even if there is enough space on the ship to provide a landing area (either full or restricted) it is recommended that the area be positioned so that a large part of the manoeuvring zone is as close to the ships side as possible. All aerial awnings, stanchions and devices in the vicinity of the manoeuvring zone should be removed or lowered. The area of operation on deck to be marked by letter H in yellow or orange with circles of yellow / orange and black alternately.

7006 **Hoist from a Rigid Survival Craft.**

- (a) Lifting will be made by single or double lifts using the standard helicopter strop. Personnel will usually remain on the exterior of the craft and be lifted from outside the hull. Persons not being immediately transferred should remain inside the craft and provide body weight to ease stability problems. Coxswains of survival craft should turn their boat into the wind and endeavour to maintain a steady course at about 4-6 knots. The helicopter will hold station on the boat and match the speed on the surface craft. A frogman may land on the craft and instruct personnel regarding the evacuation.
- (b) Coxswains should bear in mind that the down draught of the helicopter's rotor may affect the steerage and will most certainly generate spray from the surface. These will not only cause discomfort but may also impair visibility, especially on the glass surface of battened down hatches. If the weather is bad and several persons are being transferred a Hi-line operation will probably be used.

7007. **Hoist From An Inflatable Liferaft.** Liferrafts are severely affected by the down draught on helicopter rotors. Even with a sea anchor stressed considerable movement on the surface will be experienced. The possibility of the raft being capsized is also a danger that cannot be discounted. Should the raft capsize the frogman would cut open the floor to evacuate the occupants. The inflated canopy of the raft may hamper the lifting operation and on occasions it may be desirable to deflate the centre arches or pillars. Personnel would then occupy the upper part of the raft until hoist operations are complete, then cause re-inflation by means of bellows (assuming that the aircraft cannot lift all persons in one trip).

7008. **Helicopter Rescue Strop.** The standard strop is made of flax webbing and is cushioned with rubber. It is attached to the winch hook by means of two 'D' rings, and a sliding toggle is provided to secure the strop around the body of the survivor. A handling loop is normally attached to the back of the strop. Harness is also used frequently.

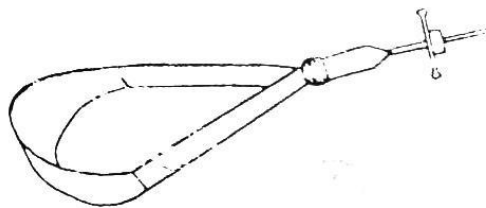

The Rescue Strop

7010. **Helicopter Pick Up.** The following procedure is to be observed in helicopter pick-up operation :

- (a) Place the head and both arms through the lifting strop.
- (b) Ensure that the strop is seated firmly under the armpits. With the padded section of the strop positioned as high as possible across the back.
- (c) Pull down the toggle to tighten the strop.
- (d) Once secure inside the strop and ready to be hoisted give a 'thumbs up' signal to the winch man or observer of the helicopter.
- (e) Place both arms down by your sides.
- (f) When level with the helicopter access, wait until instructions are received from the helicopter crew.

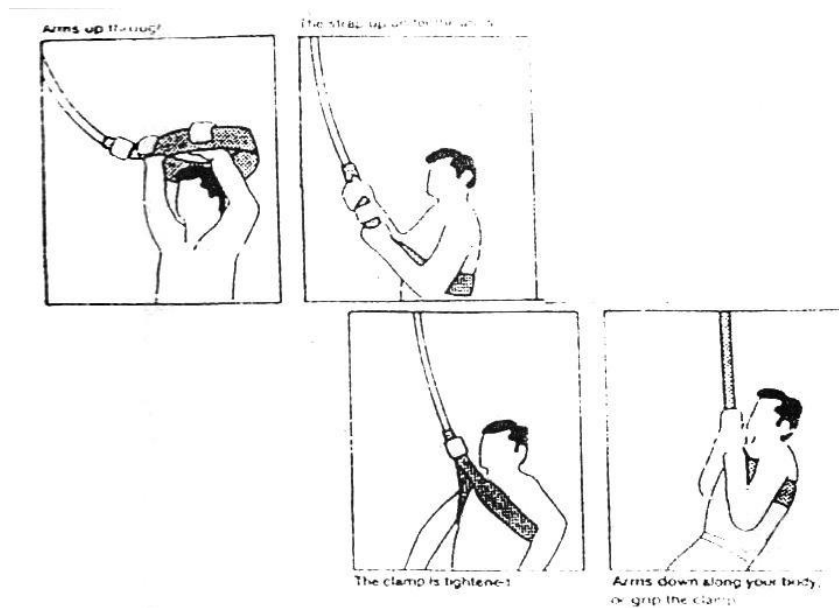

Use of Rescue Strop

7011 **Rescue Net.** The rescue net has a conical shaped 'bird case' appearance and is one on one side when the net is trailing in the water. The survivor merely enters the opening sits in the end and holds on.

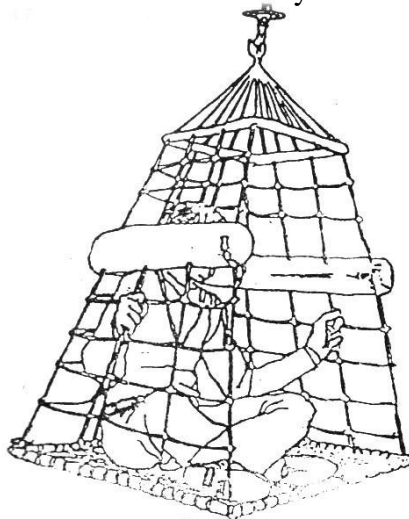

7012 **The Neil Robertson Stretcher**. This stretcher is made of canvas and is stiffened with close fitting wooden slats. It is strapped around the body of a survivor to immobilise him and to support him for the lift. It is attached to the winch hook by means of a steel ring and 4-strap harness.

7013 **General Precautions For Personnel During Winching Operations**. In the majority of cases where helicopter assistance is being given a member of the aircrew will instruct and assist in the correct method of transfer. In the event of an aircraft being engaged and when the strop only is lowered, without a frogman or winchman, the following list of precautionary measure is advised :

- (a) Do not touch the strop, winch wire or any part of the lifting hoist until the static electricity has been removed from the wire. The pilot will first earth the wire by allowing it to enter the sea or touch the deck of the ship, to remove static.
- (b) Keep the lifejacket on and place the strop over the upper part of the body; around the back and over the lifejacket. Draw down the toggle of the web straps and ensure a tight fit around your person.
- (c) Place your arms at the side (when engaged in the United Kingdom) or follow the instructions of the landing officer.
- (d) When ready to be winched up, extend your arm and given a thumbs-up signal to the aircraft, while looking towards the helicopter. Replace your arm at your side.
- (e) Once winched towards the access of the aircraft, and alongside the doorway to the cabin, remain passive; until instructed to move by the aircrew operator.

7014 **Instructions of aircrew**. In an in-flight emergency the pilot will attempt to prepare passengers for the possibility of the aircraft having to ditch. Obviously, circumstances may limit the time available for detailed explanations and any instructions by the pilot or officer in charge of the aircraft should be obeyed implicitly. The type of aircraft and the nature of the emergency will dictate the following sequence of events, as will the degree of composure and experience of passengers. On the assumption that all persons are wearing immersion suits and aviation life jackets the instructions that will be given should include.

- (a) Place immersion suit hands over heads, and close all seals to the suit.
- (b) Unpack the aviation lifejacket and place it over your head, but do not inflate the lifejacket.
- (c) Tighten up the lap strap / seat belt.
- (d) Arch the spine, gripping the underside of the legs, with feet braced firmly on the floor of the aircraft.
- (e) Brace the body, especially the head, against impact prior to the ditching point.



CHAPTER 8 – EMERGENCY RADIO EQUIPMENT

PORTABLE WATERPROOF VHF RADIO

GMDSS requirements call for ships to carry two or three portable waterproof VHF radios. These are stored on the bridge. One of the crew members is delegated to bring the radios from the bridge to the lifeboats the main use of the radios are to provide a means of communication with other lifeboats and also to liaise with rescue service as they approach. They can also be used to transmit MAYDAY broadcasts and monitor channel 16 for rescue activity. As the batteries have a maximum life of 12 hours the radios are used sparingly.

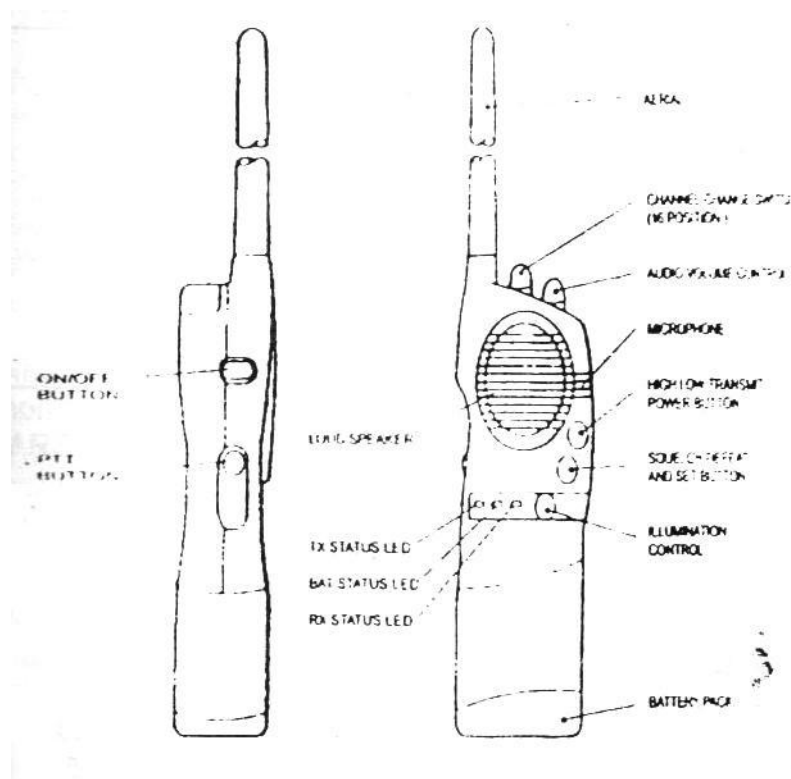

Portable Waterproof VHF Radio

- ON/OFF SWITCH : This push button turns the radio ON and OFF.
- PTT : The press to talk button must be held down to make a voice transmission.
- HI/LOW : This push button toggles the transmit power level between high (5W) and low (0.8 W)
- SWELCH : When pressed, this button defeats the squelch and can be used to set the squelch level.
- VOLUME : This rotary control varies the loudspeaker listening level to suit ambient condition.

CHANNEL SWITCH	:	This is a 16 position rotary switch.
LAMP	:	This push button illuminates the channel select dial to improve visibility.
EXLAMP	:	Indicates either HI or LOW power transmission.
BATLAMP	:	Flash when battery is nearly exhausted.
RXLAMP	:	Blink to indicate the radio is squelched.

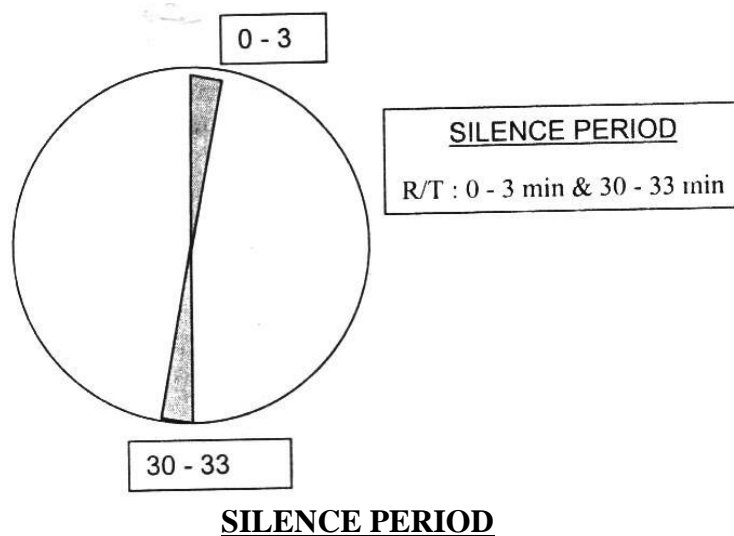

SILENCE PERIOD – A period during which no transmission is allowed. This is so that distress message from a ship requiring help/rescue is heard by other ships.

Earlier, Wireless Telegraphy was used as mode of communication, but from 1st Feb. W/T has been withdrawn and is replaced by Radio Telephony (R/T). A period of 3 mins. twice in each hours i.e. 0-3 min and 30-33 mins. passed the hour, all ships have to keep a silence NO TRANSMISSION. This is done every hour twenty four hours a day, 365 days a year. To avoid ships keeping different timings, all ships to keep their silence period as per GMT.

8001. **Emergency Position Indicating Radio Beacon.** A satellite emergency position indicating radio beacon with search and rescue capability shall be :

- (a) Capable of transmitting a distress alert through polar orbiting satellite service operating on the 406 MHz band or
- (b) If the ship is engaged only on voyages within INMARSAT Coverage (70° N or S latitude) through the INMARSAT geo stationary satellite service on the 1.6 GHz band subject to the availability of appropriate receiving and processing ground facilities for each ocean region covered by INMARSAT Satellites
- (c) Installed in easily accessible position.

- (d) Ready to be manually released and capable of being carried by one person into a survival craft.
- (e) Capable of floating if the ship sinks and of being automatically activated when afloat.
- (f) Capable of being activated manually.

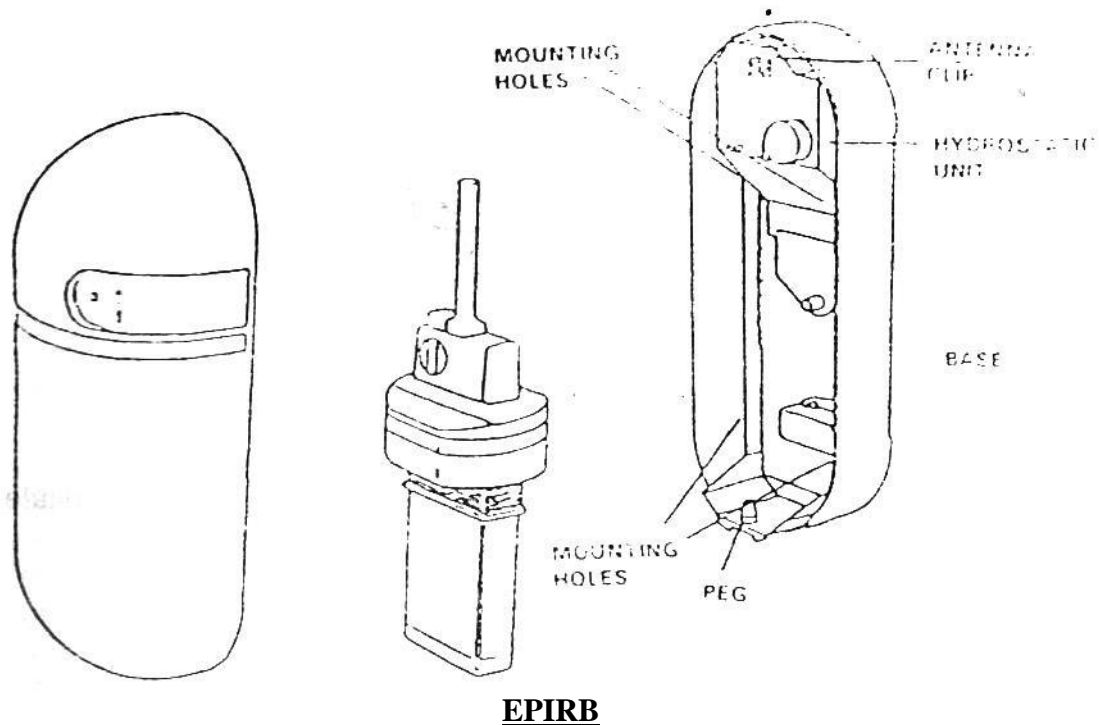

EPIRB

8002. **INMARSAT EPIRB.** Satellite EPIRB is also provided with 121.5 MHz frequency for homing facility which makes it most attractive for usage in comparison with VHF and INMARSAT EPIRB which have this short coming in addition to limited area coverage.

- (a) Sea Area A₁ means an area within radiotelephone coverage of at least one VHF coast station in which continuous DSC alerting is available.
- (b) Sea Area A₂ means an area excluding sea area A₁ within the radiotelephone coverage of at least MF Coast Station in which continuous DSC alerting is available.
- (c) Sea Area A₃ means an area, excluding sea areas A₁ and A₂ within the coverage and INMARSAT geo stationary satellite in which continuous alerting is available.
- (d) Sea Area A₄ means an area outside Sea Areas A₁, A₂ and A₃.

8003. **Float Free Emergency Position Indicating Radio Beacon.**

Operating on 406 MHz.

- (a) Capable of transmitting a distress alert to a polar orbiting satellite.
- (b) Capable of floating free automatically.

- (c) Designed so that electrical portions are watertight at a depth of 10 m for 5 minutes.
- (d) Automatically activated after floating free.
- (e) Capable of manual activation and deactivation.
- (f) Provided with means to indicate that signals are being emitted.
- (g) Capable of being dropped in the water from a height of 20 m.
- (h) Be capable of being tested without using the satellite system.
- (i) Of highly visible yellow / orange colour.
- (j) Provided with a light (0.75 cd) activated by darkness.
- (k) Has battery with capacity to operate for 48 hours.
- (l) Designed to operate in icing conditions, at relative wind speeds up to 100 knots and with ambient temperatures of -20°C to $+55^{\circ}\text{C}$.
- (m) Designed to float free at the depth of 4 m even if the ship has a trim and list of 45° .
- (n) Clearly indicated on the exterior of the equipment are operating instructions in brief and expiry date of the primary battery used.
- (o) The EPIRB signal shall include a short coded message which will give SAR authorities information concerning, the type of the beacon, manufacturers serial number and whether it has any other devices fitted. Information is stores and processed aboard the satellite and transmitted down to the next receiving ground station.

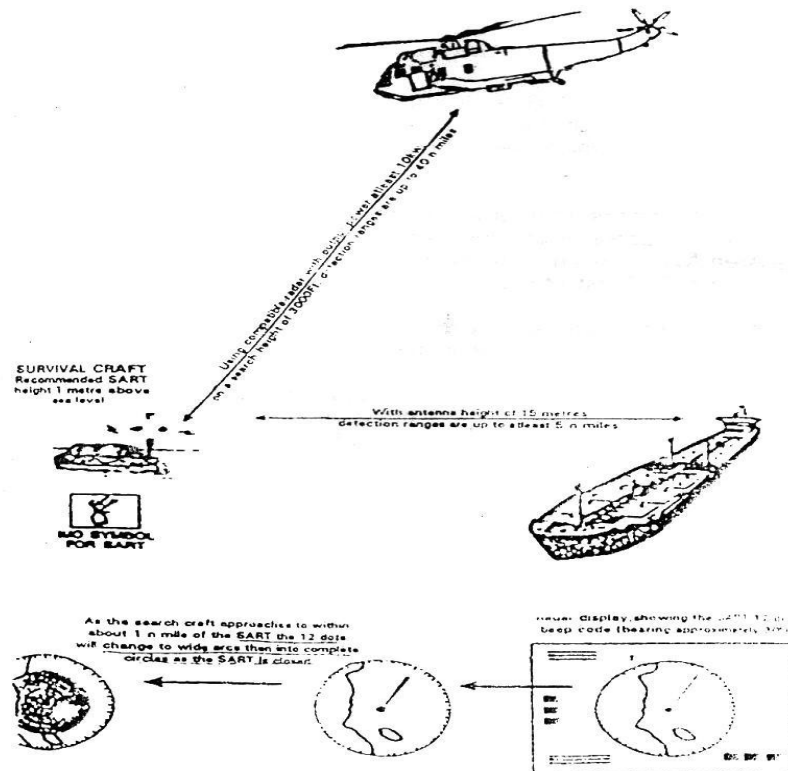

8004 **Survival Craft EPIRB**

Shall comply with all the requirements of the float free EPIRB provided that :-

- (a) Float free arrangements need not be provided.
- (b) The EPIRB shall have sufficient buoyancy to float in the water to facilitate its recovery.

8005. **Search and Rescue Radar Transponder (SART)** :

General

- (a) Shall operate on frequency of 9 GHz
- (b) Capable of indicating the location of a unit in distress on the assisting unit's radar by means of twelve equally spaced dots.
- (c) Capable of being easily activated by unskilled personnel.
- (d) Be fitted with means to prevent inadvertent activation.
- (e) Equipped with a visual and audible means to indicate correct operations and to alert the survivors that radar has triggered the locating device.
- (f) Capable of manual activation and deactivation.
- (g) Provision for automatic activation may be included.
- (h) Be provided with the indication of standby condition.
- (i) Drop tested to 20m.
- (j) Watertight to a depth of 10 m for 5 min.
- (k) Be capable of floating if it is not an integral part of the survival craft.
- (l) Equipped with a floatable lanyard.
- (m) Smooth external construction.
- (n) Highly visible yellow/orange colour.
- (o) Can operate under ambient temperatures of -20°C to $+55^{\circ}\text{C}$.
- (p) Have sufficient battery capacity to operate in a standby condition for 96 hrs. And in addition, to provide transponder transmissions for 8 hrs.
- (q) Shall have clearly indicated on the exterior brief operating instructions and expiry date of the primary battery used.
- (r) Powered by 6 x 3V (18V) Lithium Battery.

□ **Operation**

- (a) Push button switch after breaking seal – 'on'.
- (b) Hold antenna at least 1m above sea level.

- (c) When interrogated by 'X' band radar – Display on PPI ship's radar antenna 15m above sea level – 5 nm distance. On larger ships upto a distance of 8 nm from aircraft 3000 ft. above sea level – 40 m.
- (d) Display 12 dots equidistant extending from SART location along the line of bearing.
- (e) Changes to concentric circles when SART within 1 nm. 12 dots will change to wide arcs then into complete circles as SART gets closer.

□ **Self-Test**

- (a) Remove from mounting.
- (b) Push firmly switch on test position without breaking seal. After a delay of 2 to 12 sec. The test lamp will flash and bleep will sound.
- (c) Check the operation on radar.
- (d) Check only for few seconds.
- (e) After test-switch off.
- (f) Test regularly.
- (g) Battery life as per manufacturer.

8006 **Two-Way Radio Telephone Apparatus.**

- (a) Portable and capable of being used by an unskilled person.
- (b) Capable of being used for onboard communications.
- (c) Shall be operated from a battery of adequate capacity to ensure 4 hr. of operation.

8007 **Two –Way Communication System.**

- (a) This is an emergency communication system between bridge and emergency control stations, muster and embarkation stations and other strategic positions.
- (b) System shall be brought into operation from the bridge only and shall be capable of operating on both the mains and the emergency power supply.

8008 **General Emergency Alarm System**

- (a) Shall be capable of sounding the general emergency alarm signal consisting of seven or more short blasts followed by one long blast on the ship's whistle or siren and additionally on an electrically operated bell or a Klaxon, powered from the ships mains and emergency power.
- (b) To be used for calling passengers and crew to muster stations.
- (c) Audible throughout the accommodation and normal crew working spaces.
- (d) Capable of operation from navigating bridge (except for ships whistle) also from other strategic points.

CHAPTER 9 – ONBOARD TRAINING

9001 Crew should be trained not later than two weeks after joining the ship in the use of ships life-saving appliances which include survival craft equipment.

- Each crew member shall be given instructions, which shall include but not necessarily be limited.
- Operation and use of the ships inflatable liferafts.
- Hypothermia, first-aid treatment of hypothermia heat stroke, sunstroke and the treatments. Mouth to mouth artificial respiration and cardiac massage and other first-aid procedures.
- Instructions necessary for use of the ship's life-saving appliances in sever weather and sea conditions.
- On board training in the use of davit launching liferafts at intervals of not more than four months on every ship fitted with this appliances. If practicable the inflation and lowering of a liferaft kept specially for training purpose. This liferaft will be marked conspicuously.

JUMPING OVER BOARD FROM A SINKING SHIP

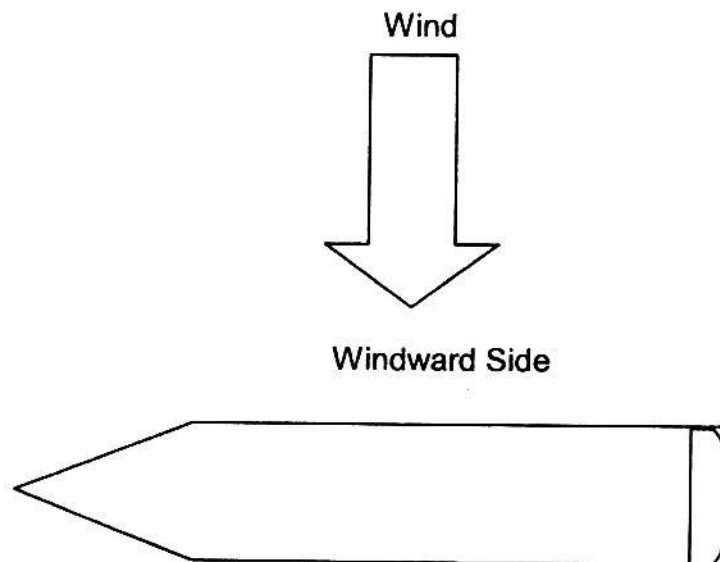

9002 Always jump on the windward side and never on the leeward side. If you jump on the leeward side due to the drift of the ship you will never be able to swim clear of the lee and when the ship sinks you will go down with ship. If you jump on the windward side you do not have to swim, the ship will drift away from you.

9003 How to Jump OVER BOARD.

Your lifejacket is tested for a height of 4.5 meters only. Climb down the life lines, embarkation ladder, the gangway safety net, the ford and aft mooring ropes but never jump from the shipside or you could injure yourself.

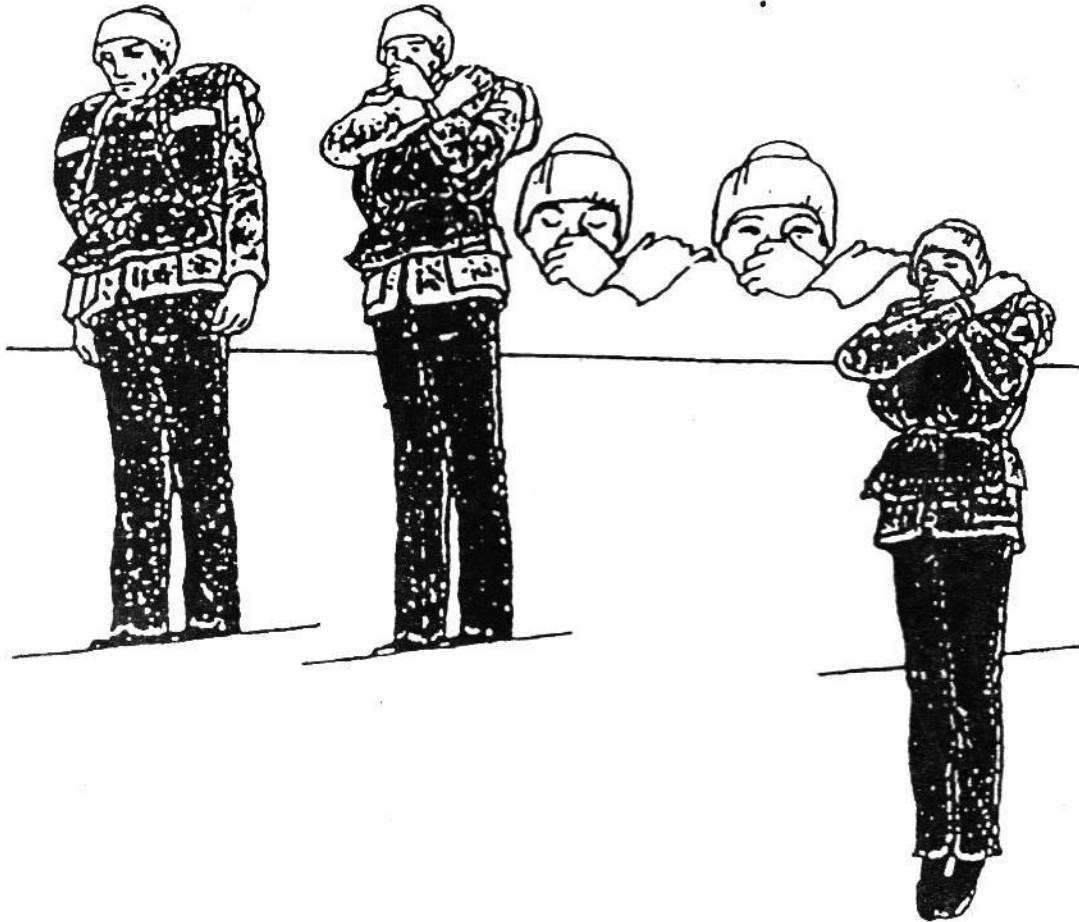

9004 Beaching Of A Lifeboat

Beaching a lifeboat in good weather is not any easy task and beaching a lifeboat in bad weather is next to impossible. Now a day no one beaches a lifeboat because every country now has helicopter rescue service.

When the lifeboat is close to shore then chose a sandy beach. It is not possible to use the lifeboat aground because the speed of the breakers is more than then speed of the lifeboat. The breakers keep hitting the stem of the lifeboat causing the propeller and the rudder to loose its steerage and with the result the lifeboat gets broadside to the sea and swell and trend to capsize.

Using the engine head towards the beach till you come to a position where the swell starts to break (breakers) then turn the lifeboat around 180 degrees to face the sea with the stern to the beach. Stop the engine and stream the sea anchor, which will keep the bows into the sea and swell. Now lash the rudder to one side and use the steering car to steer at the same time man the cars.

At the breaker hits the bow of the lifeboat the man at the bow will trip the sea anchor and at the same time the persons on the oars will back water, this will move the lifeboat astern. The man at the bow will be watching the next wave, as soon as it comes close to the bow he will release the tripping line so the lifeboat will stem the sea and swell and at the same time the oars will be taken out of the water. As soon as the next breaker hits the bow the above procedure will be repeated. In this way the boat will slowly move backwards toward the beach.

Just when the boat touches the beach some of the survivors can jump into the shallow water at the stern and start pulling the boat ashore.

If the boat capsizes in the surf it is better that all crew stay clear of the boat.

Beaching lifeboat should never be done at nighttime.

Beaching a lifeboat is not done these days as we have helicopter rescue service and coast guard.

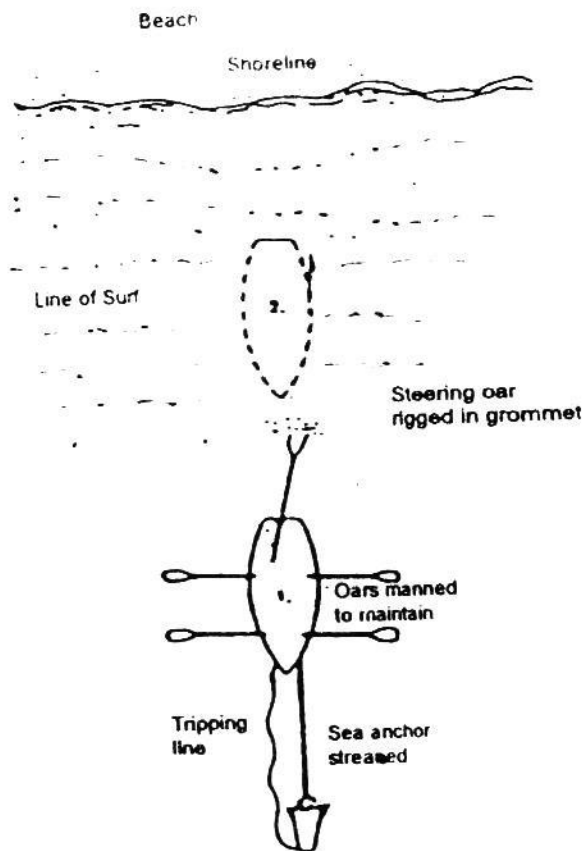

CHAPTER 10 – SURVIVAL IN COLD WEATHER

1001 Immersion Foot (Non-Freezing Cold Injury)

Immersion foot is caused by prolonged exposure of the feet and legs to cold and wet. The colder the water and longer the exposure, the greater the damage to the foot. In lifeboats every effort should be made to keep the bottom of the lifeboat dry. If this is not possible the feet should be kept out of the water as much as possible. Sea boots do not afford protection because damp and cold penetrate through them. Boots/shoes should be emptied of water and socks removed, wrung out, and put on again immediately unless a dry pair is available. Rubbing the feet to warm them is ineffective except in sunny weather since exposure to cold air chill them more than they are warmed by rubbing. If the skin has become numb and swollen, rubbing will do more harms than good. Anything that restricts the circulation of blood in the legs like tightly laced shoes should be avoided.

1002 Treatments

The patient must be encouraged to move his toes and legs as much as possible; this is the most important step in improving the circulation. In the lifeboat, he should if possible lie down with the affected leg or legs elevated and try to keep them elevated and dry. If a blister or gangrenous patch forms, the area should be covered with gauze dressing and lightly bandaged.

1003 Frostbite (Freezing Cold Injury)

Exposure to prolonged cold, especially if associated with forced inactivity, lowers the individual's vitality and results in a fall in the temperature. His limbs feel numb and heavy and later become stiff, he becomes drowsy, and if left untreated he will lapse into unconsciousness.

With frostbite the skin and sometimes the deeper tissue becomes actually frozen. At first there is local pain, which ceases as the area becomes frozen. The skin is first red, then becomes a dull creamy white and extremely hard to the touch. If left untreated the affected area, which is clearly defined, gradually increase in size. Usually the individual is unaware that frostbite has occurred and it is a companion who notices it as a yellowish white area.

1004 Treatment

Frostbite can be prevented, and rarely occurs when people are trained to protect themselves against the cold. People compelled to go out into extreme cold should wear plenty of warm dry clothing, expose themselves as little as possible to the cold, especially if they cannot take vigorous exercise, and avoid smoking. If in a lifeboat patches of frostbite are seen in a companion's face, place a warm handover them. Do not rub the patches with snow. If the limbs are frost-bitten, attempt to warm them under layers of victim's or a companion's clothing.

1005 Hypothermia

This is excessive cooling of the body. The normal body temperature is 37 degrees C. A drop of 1-degree C causes shivering and discomfort. A drop of 2 degrees C causes the body to increase its heat production to maximum shivering is extreme and the blood flow to the skin

and peripheries is reduce. Metabolism progressively decreases below 35 degree C. A drop of 3 degrees C causes amnesia, confusion and disorientation as well as cardio-respiratory abnormalities. The shivering may be replaced by muscle rigidity.

- 1) Cause : Inadequate protective against cold.
- 2) Prevention : adequate protective clothing.
- 3) Symptoms : may complain of coldness, mental and physical distress and confusion.
- 4) Signs : the skin appears white and dead looking, slurred speech, shivering, abnormal vision collapse and cardio-respiratory arrest.
- 5) Treatment : remove victim from the cold to warm shelter, prevent further heat loss and warm the patient up.

1006 **Artificial Respiration And Cardiac Resuscitation**

When the survivor is not shivering and is semi-conscious or unconscious then immediate first aid is necessary.

Always check if the survivor is breathing by putting the back of your hand near the nose of the survivor to check if the person is breathing. Also check the survivor is not breathing then make sure that the airway is clear (remove any thing stuck in the mouth, remove dentures if any). Lay the person flat on the back and tilt the persons head back so that the persons tongue does not block the airway and start artificial respiration immediately (mouth to mouth or mouth to nose) normally 12-15 times a minute.

In case the heart stops beating then cardiac resuscitation may be applied (Normally 60-80 times a minute). The main object of giving cardiac compression is to restart the heart. However you should be certain that there is no pulse before giving Cardiac resuscitation otherwise you could stop the heart. Once cardiac resuscitation is must be continued properly until the patient is either fully recovered or delivered to a hospital. The survivor should be laid down on his back on some thing hard. Then place the ball of the hand on the lower half of the sternum (breastbone), cover it with your other hand, and after each inflation of the lungs press sharply 5-6 time, at the rate of one a second. The force applied should depressed the sternum about 2.5 cm (1 inch) much less force will be required in children and younger people.

The person carrying out artificial respiration at the patient's head should be able to feel the pulse in the neck with each pressure on the sternum, and he should check it periodically to see if the heart has begun to beat again. If it does, external cardiac massage should be stopped, but artificial respiration should be continued until breathing is re-established. When only one person is there with the unconscious person then he will give two mouth to mouth followed by ten or twelve cardiac massage.

When two persons are there with the unconscious person then they will give one mouth to mouth followed by five or six cardiac massage.

1007 Survival in Hot Weather

Heat Camp. Heat camp is caused by loss of salt from excessive perspiration. It may come on suddenly in someone who has been working in the engine room or a hot compartment and sweating freely. His muscles go into contractions that in severe cases may be extremely painful, the spasms usually passing off in a minute or so but recurring unless treatment is given.

Treatment : Restore salt to the body by giving salt tablets.

Heat-Stroke or Sunstroke :

Exposure to severe heat, whether in a compartment of a ship in direct sunshine, may cause heat stroke or sunstroke. This condition is extremely serious. If the patient's life is to be saved energetic measures must be undertaken immediately. The patient is in a collapsed state, delirious or comatose, his skins hot and dry, his face and lips often blue. The diagnosis is rarely in doubt, but take his temperature in the armpit, partly for confirmation and partly to assess the urgency of the case. It may range from 40.5 to 43^o C (105 to 110^o F).

Treatment : Move the patient to a cool place and lay him flat. Remove his clothes and try to reduce his temperature by cold sponging. Remove the patient's clothes and sponge the patient from head to foot for about 20 minutes. Use a cloth or sponge dipped in tepid water. Then dry the patient and put him in some dry clothes and note his temperature.

The Pulse Rate

The pulse rate should be recorded at the same time as the temperature. It is normally taken at the wrist for a full minute, but if towards the end of the minute the rate is observed to slowing it should again be taken, since it may have, increased from nervousness and may also vary with the respiration rate.

A convenient place to feel the pulse is the wrist, it can also be felt in the neck (carotid pulse), at the temple, or anywhere where an artery lies exposed near the surface. To take the pulse place three middle finger tips on the artery. The thumb should not be used.

The number of beats per minute varies with age, but in a healthy adult between 65 and 80 may be said to be normal, a fair average pulse being about 70 to the minute.

The rate can rise during exercise, excitement, fever.

1008 The Respiratory Rate

The respiratory rate is the number of times per minute the patient breathes in and out, each breath consisting of one inspiration and one expiration. Count it by observing the rise and fall of the chest. The normal rate at rest is 1 to 18 per minute. The rate can rise during exercise, excitement, fever.